



**The Environmentally Sound Management of Used
Lead Acid Batteries and the Use and Application of
the Benchmarking Assessment Tool Workshop**

Geneva - Switzerland

October 2018

Brian Wilson – International Lead Association



BASEL / ROTTERDAM / STOCKHOLM

The Use and Application of the Benchmarking Assessment Tool for the Environmentally Sound Management of Used Lead Acid Batteries

1. Introduction

The increasing demand for cars in Worldwide, as well as the growth of Green Energy (such as solar panels) means that the demand for Lead Acid Batteries will only grow and increase the tonnage of Used Lead Acid Batteries (ULAB) in need of recycling.

If the Lead industry is not cognisant of sound environmental management and occupational safety, the International Community will likely apply pressure to improve performance in these respects. However, it is entirely possible for the Industry to make changes in the environmental agenda before the international community finds the need to intervene. To achieve such cooperation, it is necessary for regulators and Industry to work together to improve environmental performance, reduce occupational exposure and raise safety standards in a constructive and cost-effective manner. This can be done with the aid of the the Benchmarking Assessment Tool.

In the framework outlined the workshop addressed:

- How the Benchmarking Assessment Tool (BAT) can be used as part of the licensing process for ULAB recycling plants
- How to be sustainable, environmentally sound and profitable
- How Industry and State regulators can work together to reduce the number of sub-standard operations
- How to apply the Benchmarking Assessment Tool to improve recycling efficiency, profitability, safety, occupational health and environmental performance in a constructive manner

2. The Supply of ULAB in an Environmentally Sound Manner

Governments are aware of the toxic consequences of improper ULAB recycling and should be ensuring that regulations for the environmentally sound management and safe handling of used lead-acid batteries are consistent with the Basel Technical Guidelines and domestic legislation. Recycling valuable resources such as ULAB is essential to a national or regional economy and a domestic LAB manufacturing sector, and more so today as the energy storage media for Green Energy Generation is the Lead Acid Battery and this is a market with the highest growth rate for LAB use.

The Basel Convention for the Control of Transboundary Movements of Hazardous Wastes and Their Disposal exists to facilitate the controlled and environmentally sound disposal or recycling of hazardous and non-hazardous wastes. There are published guidelines that define what is meant by the environmentally sound management of ULAB. Strict adherence to the Basel Convention Guidelines for the Environmentally Sound Management (ESM) of ULAB would mean that only whole un-drained ULAB, that is, complete with electrolyte, would be delivered to the secondary Lead smelters.

However, this is not always the case and all too often the battery electrolyte is drained from the ULAB before it is transported to the smelter.

3. Sustainable, Environmentally Sound and Profitable Recycling

Outlined below are examples of practical and viable options for the environmentally sound management of Used Lead Acid Batteries. Failure to follow the correct management procedures could result in adverse health risks. However, these risks can be mitigated by following sound and proven procedures that minimise the health, safety and environmental risks. The entire ULAB process can therefore be made safe and profitable with careful planning and handling, reducing the amount of hazardous waste produced during processing.

Following the correct procedures make the difference between a licensed environmentally sound business and an unorganised, unregulated polluting sector, both in terms of the viability, health risks and the ESM.

There are five key steps in the recycling process for ULAB:

1. The collection of the ULAB, packaging and transportation to the smelter
2. ULAB draining or containing of the acidic electrolyte and its treatment for disposal, reuse or conversion to a saleable product.
3. The separation of the organics, that is, the plastics and the non-organics, (the metallics and the battery paste)
4. Smelting of the grid metallic, the Lead battery paste and recycling of the terminals/posts.
5. Refining the Lead bullion (the unrefined metal tapped from the furnace) for sale.

The Process Phases in the Recycling of ULAB

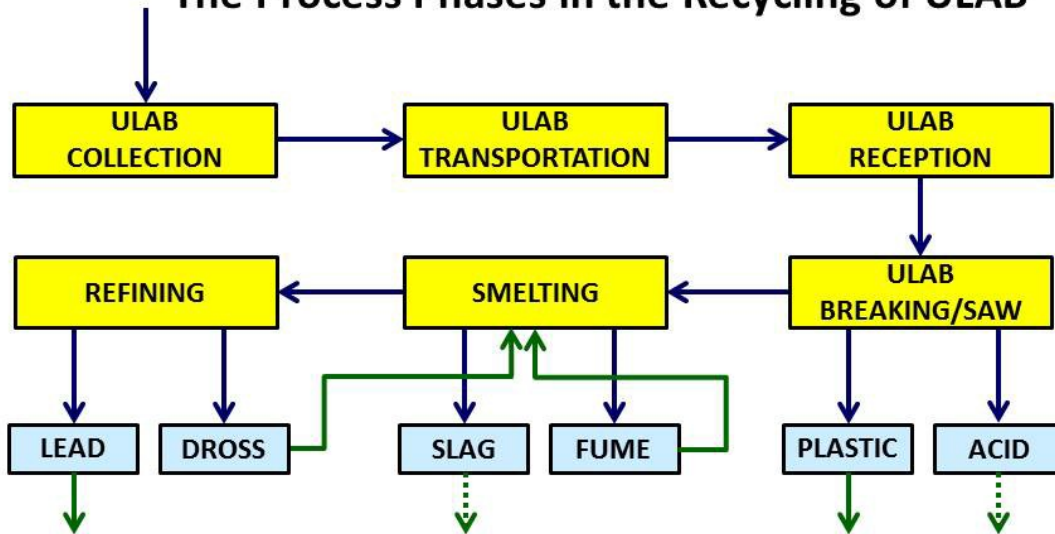

The process flow chart shows the ULAB Collection, Transportation, and Reception. It shows the breaking of the ULAB to separate the plastic, acidic and metal components, the smelting of the metal fractions and extracting impurities in the Slag, (with any dust generated captured by the Baghouse or Filter plant). The final step is the refining of the Lead Bullion to remove any remaining impurities (removed as a by-product called a dross) and cast the pure Lead ingots (99.97% or 99.99%).

Currently there are two pyrometallurgical processes that are popular with Smelters in most low and middle-income countries and particularly suited to small scale operations, that is about 50,000 tons of Lead production per annum. The two processes are the:

- ❖ Rotary Furnace
- ❖ Blast Furnace

The Blast Furnace will not be discussed in detail here because this technology is being phased out across the globe in favour of more flexible technologies that recycle all the by-products efficiently, and ones that are more energy efficient.

The first stage in the recycling process is the recovery of ULAB. The batteries should be collected with the battery electrolyte and not drained. They should be stored in an upright position and sorted by size. Prior to transportation to a smelter, the ULAB should be either transferred to a leak proof plastic container especially designed and UN approved to transport ULAB or shrink wrapped and stacked on a pallet in three or four layers.



UN Approved Container for ULAB



Shrink Wrapped and Palletized

The degree of stacking will depend on the height of the ULAB. Between the layers of ULAB, thick cardboard should be placed to prevent any movement during transit. Finally, the ULAB should be shrink-wrapped to prevent movement during transit. Using a UN approved, plastic and leak-proof container for the collection of ULAB would allow the ULAB can be transported in any vehicle.

In addition to all the precautions outlined above, the vehicles used to transport the ULAB should be dedicated to the task, licensed to transport hazardous waste, display the necessary decals that define the waste, as well as the hazards associated with the waste and an emergency contact number.

Depending on the process, the battery electrolyte will be separated either prior to breaking or during breaking, depending on whether a battery saw is being used or a hammer mill, but whatever the process might be, the treatment process for the disposal or reuse of the electrolyte is the same.

Ideally, the battery electrolyte should be recovered, reconditioned and returned to the Lead Acid Battery (LAB) manufactures to fill new batteries. However, only a few recycling plants have such processes and investment in the necessary equipment has, up to now, been too expensive to make reconditioning a viable process. But the Chemists at Wirtz Manufacturing (USA) have developed a reconditioning process that is suitable for SMEs, because it is inexpensive, and it produces dilute sulfuric acid that can be rendered suitable for sale to LAB manufactures. Alternatively, the acidic electrolyte can be neutralized and there are three ways this can be achieved.

The first stage involves adding sodium hydroxide to the electrolyte to produce sodium sulfate and water, and in a similar manner, sodium carbonate can be added to also produce sodium sulfate and water, but this process will also liberate carbon dioxide.

Sodium sulfate, is used in the manufacture of glass, soaps, and detergents, but purification involves vacuum distillation and the equipment is expensive and not necessarily suitable for an SME in a developing nation or one with an economy in transition.

The third option has been widely adopted by SME across the globe. Basically, lime or Calcium Hydroxide is added to the acidic electrolyte and mixed thoroughly to precipitate Calcium Sulfate, better known as Gypsum. Gypsum is a saleable product and can be sold to the cement industry and can be found in almost all forms of wall boarding. More recently such materials could be incorporated into a cement mix with furnace slag to produce non-leachable paving slabs.



Indonesian Paving Slabs

The majority of ULAB recycling plants have chosen to purchase a Battery Breaker with a hammer mill to break the ULAB. There is no doubt that the breakers perform well and achieve a good hydro-gravitational separation of the battery components, that is, into plastics, grid metallics and paste, but they can be expensive to buy and operate.



Hammer Mill ULAB Breaker (*Courtesy of Gravita India*)

A cheaper alternative approved by the Occupational Safety and Hygiene Administration (OSHA) of America, is the battery saw¹. It is fast, efficient and perfectly safe, provided it is ventilated to prevent acid mist build up in proximity to the saw.



Ventilated Battery Saw (*Courtesy of Gravita India and Eco Global*)

¹ https://www.osha.gov/SLTC/etools/leadsmelter/popups/batterysaw_popup.html

The saw removes the top section of the battery exposing the plates containing the grids and the paste. The grids are easily removed and placed in suitable charge bins in preparation for smelting. The polypropylene cases are washed and sold to a specialist plastic recycler.

The advantages for the SME is that it is possible to separate the white and coloured plastic and obtain the higher price for the white polypropylene.

The installation of a pelletizer will also add value to the recovered polypropylene and the neutralized effluent, once filtered can be used for the first rinse of the polypropylene chips to remove the final traces of oxides and sulfates.

What must be considered is that the battery paste consists of Lead oxides and Lead Sulfate. During smelting, Lead Sulfate will break down as the Lead component is extracted and sulphur dioxide will be released. Sulphur dioxide gas combined with water, such as mist or rain, forms dilute sulfuric acid. This is where the term "Acid Rain" comes from, and this is something to be avoided, and so it must be removed from the furnace off-gas for the stack emissions to comply with national standards and international norms.

There are essentially three options for the removal of sulfur from the battery paste:

- Before smelting
- During smelting
- After smelting

Beginning with the process of de-sulfurization prior to smelting and there are two options to consider.

The first option is similar to the second method already discussed for the treatment of the battery electrolyte and that is, the addition of Sodium Carbonate into a stirred slurry of the battery paste containing Lead Sulfate in a mixing vessel.

This is a slow process, but eventually Lead Sulfate will be converted into Lead Carbonate, which is precipitated, and Sodium Sulfate will be in solution. The Lead Carbonate can be charged to the furnace and will decompose into Lead Oxide and Carbon Dioxide. We will look at the furnace operation shortly and will consider the manner in which the Lead is extracted from the Lead Oxide later.

There is one further use for Sodium Sulfate that was not listed earlier and that is in the paper industry. In 1883 Carl Dahl invented the "Kraft Process" for paper making. Kraft in the German language means "Strength" or "Stronger" and what Carl Dahl found out was that by adding sodium sulfate to the paper pulp mix, the paper was strengthened considerably.

Option 2 involves mixing Ammonium Carbonate with the Lead Paste so that it reacts with the Lead Sulfate to form Lead Carbonate and Ammonium Sulfate. Ammonium Sulfate is a fertilizer and a rich source of nitrogen.

Turning hazardous waste into a fertilizer is a great use of resources. This process to convert the battery electrolyte (dilute sulfuric acid) into a fertilizer was developed and is now marketed by Engitec of Italy.

The image below features a typical Rotary furnace with the burner mounted at the rear of the drum with ventilation hoods at the front and rear of the furnace. The ventilation hood at the front (on the left of the image) captures the dust and fume during charging and tapping and the ventilation hood at the rear captures the combustion off-gases.



Rotary Furnace (Courtesy of Pb Metal Ltd.)

However, in the schematic below the shows a furnace with a centre tapping hole that comprises of a steel drum that is lined with refractories to protect the metal during the smelting operation. The burner can be fired using reclaimed oil, or gas or a mix of either fuel with oxygen and it can be mounted in the door or at the rear of the furnace.

Rotary Furnace – Centre Tap

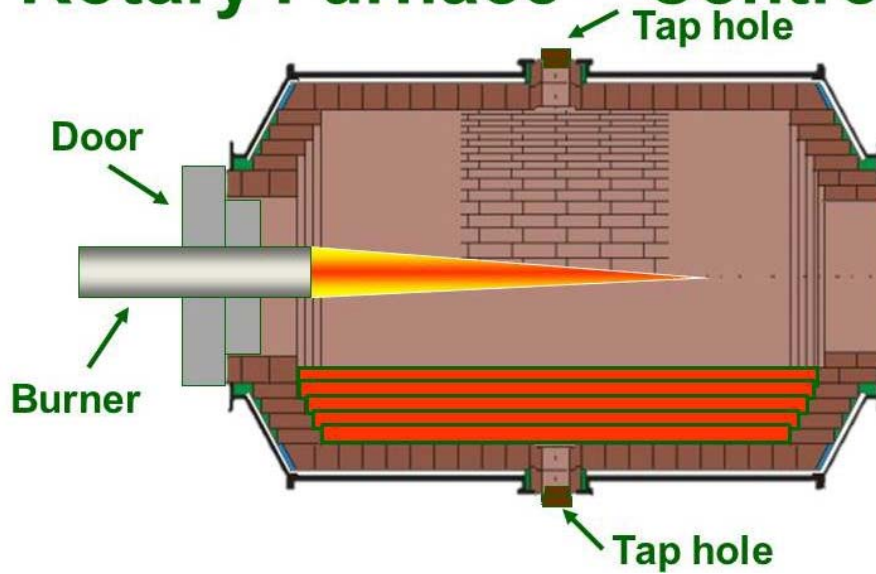

And this is the configuration for the location of the tap holes at the front of the furnace and here is a typical tapping operation for such a furnace.

Rotary Furnace – Front Tap

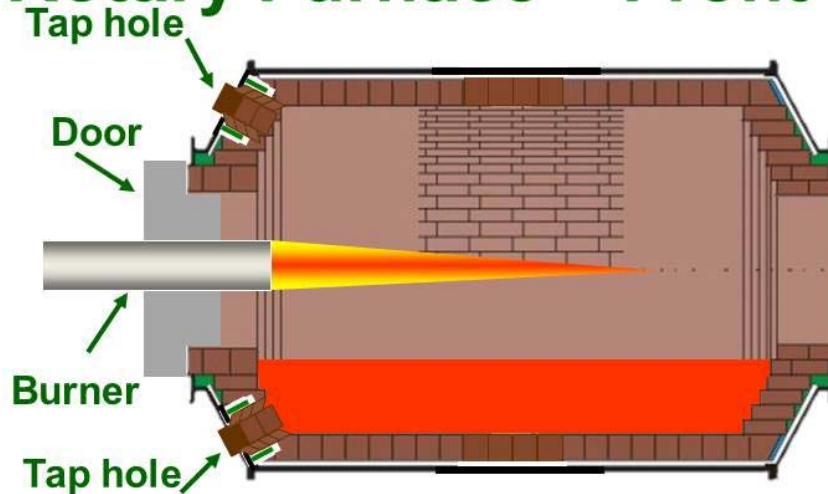

If the burner is mounted at the rear of the furnace, it is more energy efficient because the heat from the burner has a double pass through the furnace before it escapes into the combustion flue.

Reverberatory Rotary – Rear Burner

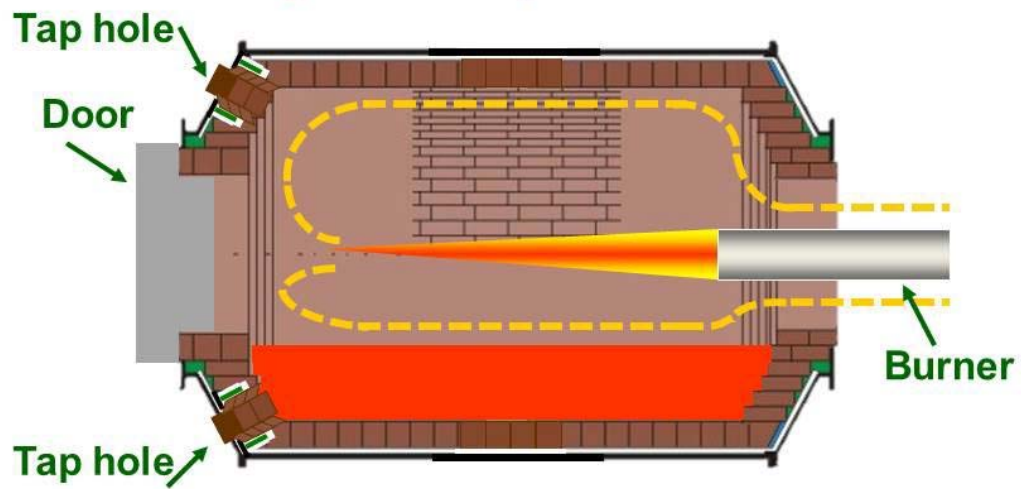

A third method of tapping the Rotary furnace is through the front-loading port by tilting the furnace drum from the rear.

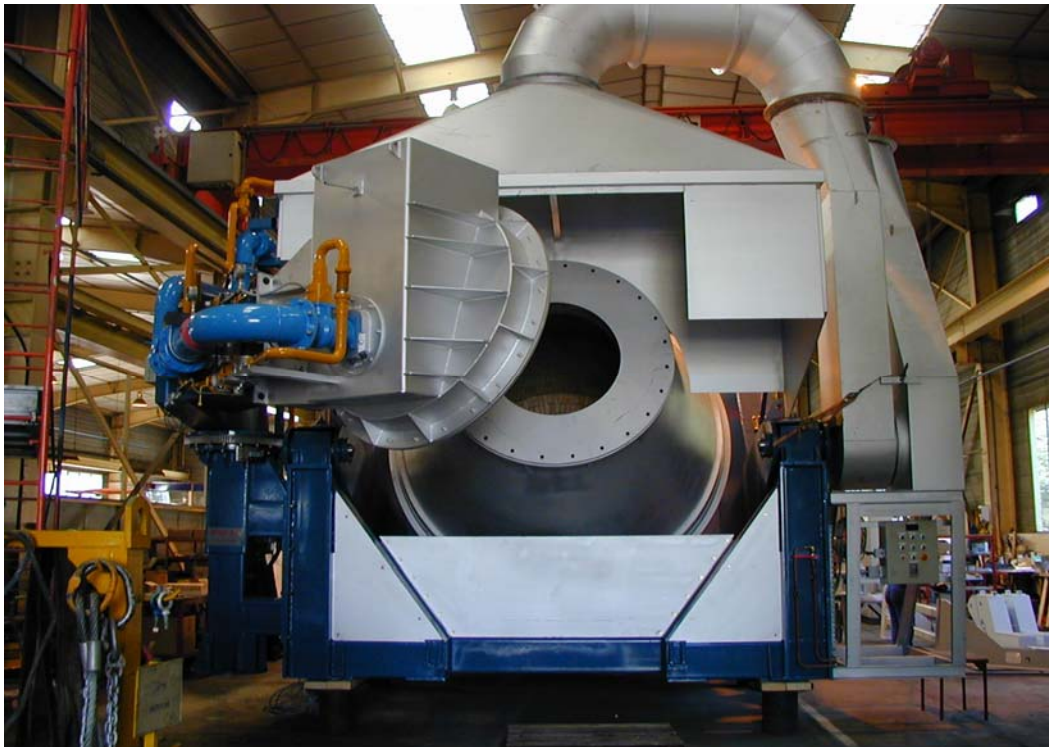

Tilting Rotary Furnace (Courtesy of Dross Engineering)

For those smelters with a centre tapping port, the only way to effectively contain the fume emissions during tapping is to encapsulate the whole furnace and keep it completely enclosed during tapping.



Encapsulated Centre Tapping Furnace (*Courtesy of Gravita India*)

The de-sulfurization process that takes place during smelting, is simply a process that adds scrap Iron to the charge material, and it can be scrap steel, such as oil drums and thin steel plates.

What happens during smelting if the sulfur is not removed prior to smelting is that the Lead Sulfate is reduced by the Carbon contained in the coal fines added to the furnace charge to form Lead Sulfide and Carbon Dioxide. The Lead Sulfide then reacts with the Iron to release the metallic Lead and the Iron Sulfide formed is captured in the slag.

The addition of Sodium Carbonate in the furnace charge also assists with the Sulfur capture by reacting with the Lead Sulfate, the Iron and the Carbon to release the metallic Lead forms a complex Iron, Sodium and Sulfur compound that eventually stabilizes to form a residue that is known as Erdite Slag. At the same time carbon monoxide and carbon dioxide are also formed. The Carbon Monoxide formed is also consumed in the smelting operation as a reducing agent.

The Lead Dioxide in the paste is reduced by the Carbon at a relatively low temperature to Lead Monoxide and is itself reduced by either the Carbon Monoxide to Metallic Lead and Carbon Dioxide, or the Carbon to metallic Lead and Carbon Monoxide.

This simple and inexpensive process will remove up to 95% of the Sulfur from the charge material.

If Iron and Sodium Carbonate are not added the smelting mix, then the Lead Sulfate in the paste would be reduced to Lead Monoxide, but in addition to releasing Carbon Monoxide, Sulfur Dioxide would be released and will enter the atmosphere unless it can be contained before it is released through the chimney stack, and that is the cue to consider de-sulfurization after smelting.

There are several options, but consideration will be given to the two most common. Both options require the use of a Scrubbing Tower, which is essentially a tall steel vessel that has a solution of either sodium carbonate or Calcium Carbonate sprayed into the chamber from the top of the vessel.

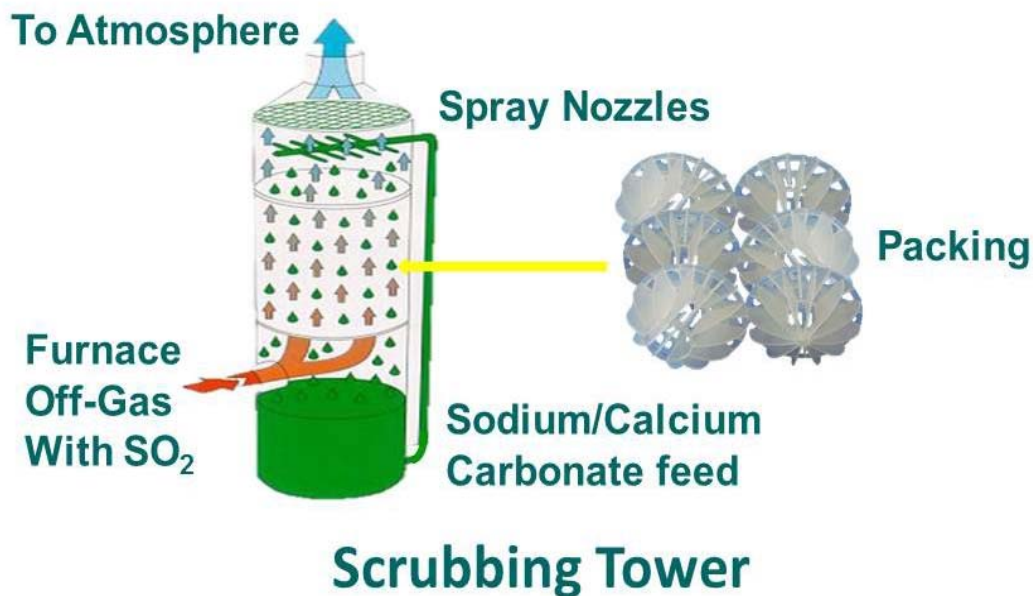

The alkaline solution passes over thousands of plastic fillers or spacers that effectively increase the surface area of the liquid, thereby enabling more opportunities for contact between the furnace off-gas entering the tower at the base and the alkaline solution.

The reactions are typically the absorption of the sulphur dioxide for either the Calcium Sulfate or Sodium Sulfate options, and the liberation of Carbon Dioxide gas. The Calcium and Sodium Sulfates will be in solution, but the salts can be recovered in a manner similar to that described earlier to produce saleable products.

A well-managed scrubber tower will remove 99% of the Sulfur Dioxide contained in the Off-Gas. Increasingly over the past decade more and more operations are choosing two of the three options to ensure that the stack emissions are free of sulphur dioxide.

Lime is normally chosen to make the alkaline wash and the Gypsum produced can be sold or used in the production of paving slabs. It is also more common to find that modern smelters choose the first two options, that is, before and during smelting, rather than relying on the third option alone, because if that fails, then there are no further processes to remove the sulfur dioxide.

Extraction ventilation systems are a very important aspect of plant management and occupational health. Typically, on a front tapping Rotary Furnace the Hygiene Ventilation Hooding is located at the front of the drum and Combustion Ventilation ducting at the rear of the drum.

However, it is difficult to capture all the fume and dust generated during tapping from a Rotary Furnace with centre tap holes, because the emissions tend to creep round the drum and escape capture and so the only effective solution is to encapsulate the whole furnace and ventilate the box.

Any fumes or dust generated at any stage of the recycling process will be extracted through the ventilation ducts to a filter plant, or Baghouse, where the dust is removed, collected and the By-Product returned to the furnace with the next charge to recover the Lead.

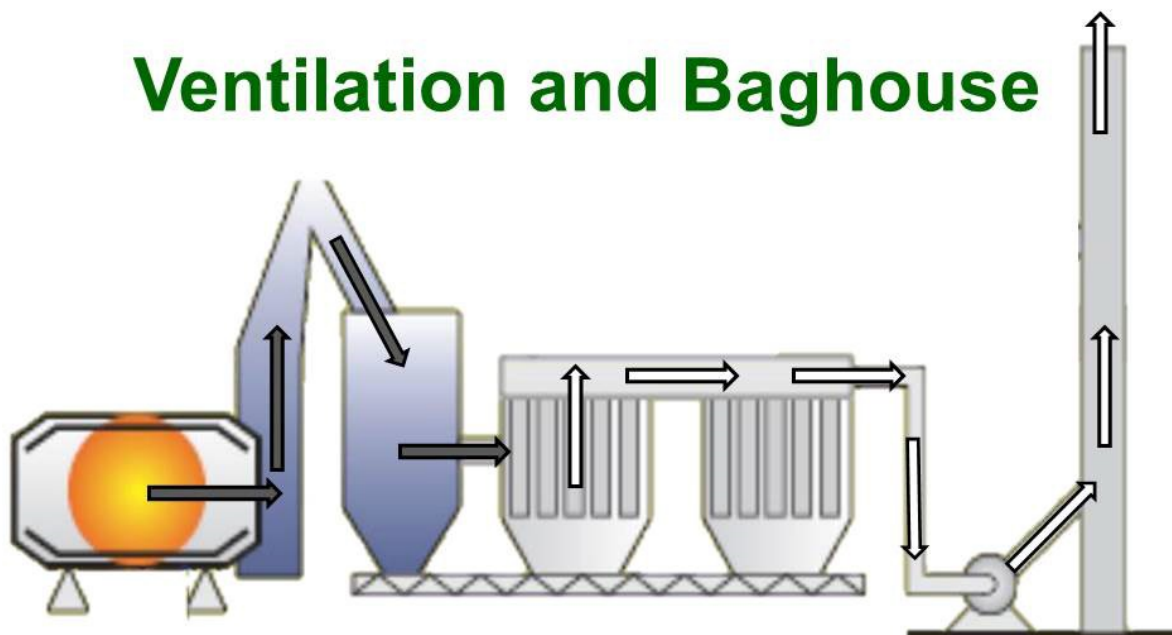

The Baghouse operates such that the Furnace Off-Gas exits at the rear of the drum into the combustion flue and then a drop out box, that effectively slow down the velocity of the gas to enable any large particulates to literally “drop out” and fall to the floor of the chamber. The dust laden gases then pass through a filter bag, shaped like a sock, from the inside to the outside, leaving the dust particles on the inside of the “sock”. The clean gases are then ejected to atmosphere.

At set intervals, one compartment in the Baghouse will shut down to permit the dust collected to be either air pulsed or shaken free of the filter lining. During this operation another compartment in the Baghouse will open and filter the dust from the Furnace Off-Gases.

The dusts are ejected from the Baghouse through a non-returnable valve into a collection drum and the material returned to the furnace to recover the Lead.

The other issue that must be addressed is the furnace residue or slag. Competent recycling operations will achieve very low lead contents in the furnace slag, down to 1% or less, but in many countries the slag is still classified as a hazardous substance and consideration must be given as to which disposal or reuse option to select as there may be implications relating to hazardous waste regulations.

For example, in Colombia, there was a project running to produce high end decorative ceramic bricks that pass the construction industry’s standards for Lead content and leaching.

In Indonesia, one company is already producing decorative Paving Slabs on a commercial scale from a formulation that includes approximately 15% of Lead Slag in the mix. The paving slabs comply with building regulations and are very stable.

It is important to keep the smelter workplace clean, tidy, dust and debris free and damped down. In this way the risk of Lead dust in the working environment is reduced and a safe place of work maintained.

However, the following Guidelines should be adopted to minimize the risks associated with occupational Lead exposure.

1. Always wear the correct Personal Protective Equipment (PPE) proscribed for the job.
2. Ventilate all the control rooms with HEPA filtered air and maintain a positive pressure to ensure dust does not enter the room as staff enter and leave the control area.

3. Clean work clothes should be worn every day or shift.
4. Every worker employed in the smelting area must shower before leaving the plant at the end of the day or shift.
5. A clean canteen under positive pressure with HEPA filtered air should be provided.

Essential to any Lead Smelter as a minimum requirement is that everyone must wear a hard hat, goggles and dust respirator.

If dust masks are issued instead of Neoprene respirators, then they must be fitted with exhaust valves to reduce condensation problems.

Most important of all of course with any respirator is that it fits correctly and provides a perfect seal around the face to prevent the ingress of dust. It is therefore most important to ensure that the nose clip is pushed into place to create a seal between the nose and the mask.

Although the neoprene respirators and the dust masks will suffice for the vast majority of tasks in the smelter, there are certain jobs that require a higher level of PPE, namely working in the Baghouse for whatever reason.

When working in a Baghouse wear a full-face mask and a coverall, but most important of all is that when an operator or fitter has finished the job they must shower and remove any dust BEFORE they remove any protective equipment.

More and more furnace tapping operations are becoming remotely controlled, but where it is necessary to tap the furnace manually, full PPE that protects against heat and molten metal splashes as well as a full-face visor and leather furnace gloves must be worn.

Having committed to supplying the appropriate PPE and clean work clothes, adequate laundry provisions must be made, whether that is on- site or off-site, and changing rooms should be clean and free of any dust.

The clean and plant sides of the changing room should be segregated so that work clothing and clean clothes worn to go home are not mixed and all operators must shower at the end of the day or shift.

Likewise, the showers should be subject to regular cleaning and always supplied with soap.

All works clothing should stay at the plant and operators should only wear their own clean clothes when they leave work to return home.

It is also essential to provide a clean air-conditioned canteen where the workers can enjoy their meals without risk of Lead ingestion.

What is the Benchmarking Tool for the Recovery and Recycling of ULAB?

While it is important to have guidelines for the recovery of Used Lead Acid Batteries (ULAB), Standards for Safety, Occupational Health and Environmental Performance, and commitments to Sustainable Development. However, without independent inspection, monitoring, evaluation and verification, there is no guarantee of conformance with Good Practice or compliance with prevailing legislation.

What is the Benchmarking Tool for the Recovery and Recycling of ULAB?

It is equally important that any monitoring tool provides a comprehensive and easy to use evaluation process that is consistent with the International Lead Association's (ILA) Guidance Notes, the Basel Convention Technical Guidelines, and national and regional legislation, and includes safety, hygiene & sustainability.

The Benchmarking Form is a questionnaire and it was designed this way to ensure the questions provide a consistent approach to each assessment and it also means that the Benchmarking Assessment can be made without being an expert in the Technical Guidelines or the Best Practice for ULAB recycling.

The questions are also designed so that compliance with good practice or non-compliance can be identified depending on whether the ticks are in the green zones.

The Benchmarking Tool is suitable for the Assessment of Environmental Performance of any phase in the Life Cycle of the Lead Acid Battery from the Mining of Lead Bearing Ore, through Smelting, Lead Refining, Battery Manufacture, Retailing, Used Lead Acid Battery (ULAB) Recovery and Recycling, but for our purposes today we will focus on ULAB recovery and recycling.

Comparison between Regulatory Inspection and the ESM Assessment Tool

Firstly, it is a pre-requisite of any Assessment Process that a Company, a Site, a Factory, a Mine or a collection centre, complies with all the regional, national regulatory requirements and international conventions that are applicable. So, Site inspections by Government Environmental, Health and Safety Agencies are an essential and integral part of the ESM Process for ULAB recovery.

It is important to consider the differences between a Regulatory Inspection by a Government Agency and an Inspection using the Benchmarking Assessment Tool.

First, the Regulatory Inspection will specifically target one particular aspect of the operation, such as Lead Emissions, Lead in Blood levels of the workers, Effluent Discharge or Hazardous Waste Disposal, whereas the Benchmarking ESM Assessment Tool is Holistic in its approach and examines the whole recovery process in order to ensure that there is the minimum of environmental and health impacts during the recovery phases including collection, temporary storage, packaging and transport.

Secondly, a Regulatory Inspection will normally be made at one location, whereas a Benchmarking Assessment will inspect several locations associated with the ULAB recovery chain to ensure a consistent approach to ESM during each recovery phase or link in the supply chain.

The regulators will take emission and discharge samples for quantitative analysis to determine environmental performance, whereas the Benchmark assessment will be qualitative by observing the recycling operations and the methodologies employed.

A Regulatory Inspection is reactive, because it is sampling, checking or observing outcomes recorded on data sheets which will be past events by the time they are analysed, whereas the Benchmarking Tool and process directs you towards prevention and a pro-active approach to ESM by examining the process components, the operations and the control measures in real time.

Comparison Case Study

These are the questions that assessors should be asking as they conduct any assessment:

- Is this an acceptable practice?
- How would the Government monitor that situation?
- Is this operation necessary and if not, why not?
- What could be suggested to improve the working conditions or the environmental performance?

Benchmarks for ULAB Recycling

The Benchmarks for the determination of Environmental Performance at the various stages in the Lead Acid Battery Life Cycle are:

- ULAB collection
- Temporary Storage
- Packaging
- Transportation
- Recycling

Having identified the five key phases in the recovery and recycling process for ULAB, it is very important to base the Benchmarks for each phase on procedures, processes and methodologies that have a proven track record for sound environmental management, occupational health and safety.

Benchmarks for ULAB Recycling ULAB Collection

Examining, the benchmarking criteria in more detail, for ULAB Collection, it is essential that:

- *Whole ULAB are collected – Not drained of electrolyte*
- *ULAB are stacked upright with inspection caps in place to prevent spillage*
- *There is a separate plastic container for any leaking ULAB*
- *Operators wear their Personal Protective Equipment (PPE) – Rubber gloves and safety footwear as a minimum*

Benchmarks for ULAB Recycling Temporary Storage

And for Temporary Storage it is essential to have:

- *A Covered Storage Area to prevent surface water contamination from heavy rain*
- *Concrete floor with drainage sump to contain any spillage*
- *Clearly marked areas of work and pedestrian walkways*
- *Eye wash station to ensure that any splashes of electrolyte to the face are removed with clean sterile water*

Benchmarks for ULAB Recycling Packaging

Packing can be undertaken in the Temporary Storage Areas, or a retail outlet, but wherever it is undertaken the Benchmarks are the same:

- *ULAB are sized and sorted by type so that when they are palletized the rows of ULAB are even and the pallets can be stacked safely*
- *ULAB are tested to determine if they are discharged and spent, if not they should be recharged and sold as a “recharged battery”. Under NO circumstances should a ULAB be reconditioned – that is put back into service with cells cannibalized from another ULAB.*
- *Palletized in neat rows with thick cardboard, to absorb any minor leakage of electrolyte, placed between each layer of ULAB.*
- *Shrink wrapped with plastic film and strapped on all 4 sides with heavy duty plastic strapping to hold the ULAB in place without any movement during transport to the smelter.*

Benchmarks for ULAB Recycling Transportation

Because the transportation of ULAB is normally on public roads proper management of ULAB is very important. The key benchmarks are;

- *In many countries ULABs are classified as a Hazardous Waste, as they are under the Basel Convention, and so Companies that transport ULAB from the collection centres or retailers to the recycling plants require a license or an authorisation from the local authority and it is necessary to check the local situation.*
- *ULAB are palletized, shrink wrapped and strapped securely to the pallet, or are in a plastic purpose built leak-proof container, suitably braced and wedged into the back of the vehicle to prevent any movement during the delivery run to the smelter.*
- *In countries where ULABs are classified as Hazardous Waste, vehicles transporting such materials must display the appropriate Hazard warning signs externally on the vehicle, and where this is not a legal requirement, a suitable sign should be displayed so that emergency services are notified of the contents in the event of an accident.*

- *Finally, it is important that the vehicle transporting the ULAB is suitable for the task, preferably enclosed or high sided with drop down sides and that the driver is trained to deal with any minor spillages during transit or apply first aid if anyone is splashed with electrolyte.*

Benchmarks for ULAB Recycling Recycling ULAB

As Recycling of ULAB is much more complicated than Collection, Storage, Packaging and Transportation, the Benchmarking assignments are divided into four distinct categories and examined in turn. And the categories are:

- ***Environment***
- ***Safety***
- ***Hygiene***
- ***Operating Practices***

Benchmarks for ULAB Recycling Recycling ULAB - Environment

Considering the ideal conditions for maintaining the ESM of ULAB recycling the Benchmarks for the Environment should include:

- *Baghouse and emission control systems must operate in a manner so that plant emissions are within the permissible legal limits and are non-polluting or toxic. Blast furnace operations must include a scrubber to remove sulfur dioxide.*
- *To avoid any effluent discharge issues, plant effluent should be treated and then used to produce saleable by-products and the remainder used as process water or evaporated either naturally or by recirculation through heat exchangers located in the furnace off gas system.*
- *Furnace residues should be inert or rendered inert so that only non- hazardous solid waste is discharged from the site, or the waste is converted into a saleable product such as ceramic bricks.*
- *Company policy and operating procedures must be designed and implemented so that the Recycling Site remains pollution free and reusable should the smelter close or move to another site, in other words there must be a program to always have a Sustainable site.*

Benchmarks for ULAB Recycling ULAB - Safety

It is as important for a recycling plant to operate in a safe manner as it is for the operation to be environmentally sound. However, there are many aspects to Safety Management, but the Benchmarking focuses on the main issues and these can be summarized in four key Benchmarks:

- *The Company Safety Policy must be a clear commitment to the highest standards of safety for all plant personnel and anyone visiting or working at the plant for a short period. Furthermore, it must be published on the company web site and available for inspection.*
- *All workers on the site must attend a comprehensive Safety Induction*
- *All personnel working in the operating areas must always wear the appropriate specified PPE*
- *Any maintenance or engineering work must be authorised through a rigid “Permit to Work” procedure to ensure the proper safety conditions are applied and any live plant is “Locked-Off” prior to the start of any work.*

Benchmarks for ULAB Recycling ULAB - Hygiene

The health of workers and the local population are paramount if a ULAB Recycling Plant is to operate in the modern era. So, Benchmarks for Occupational Health are critical and should contain these key elements:

- *Comprehensive Occupational Health Policy covering male and female employees that stipulates the conditions applicable to plant operations to minimise any adverse health risks to employees and the local population.*
- *All workers on the site must wear and use correctly the appropriate PPE to minimise Lead exposure in the operating area.*
- *There must be in place a pro-active medical surveillance program under the guidance of a Medical Officer suitably qualified to advise the Company and workers on matters related to Occupational Health. The program must include periodic checks on the Lead in Blood levels of employees.*
- *All personnel on site working in exposed areas must be provided with clean and segregated changing rooms and clean work clothes every day. In addition, workers must be provided with a clean canteen to eat meals when at the plant.*

Benchmark Phases for ULAB Recycling – Operating Practices

When considering Operating Practices, it is not an easy task to identify four key benchmarks and lists may vary, but all are valid. The challenge is to select those that are vital for the development of the Ghanaian Recycling Industry, and they are:

- *First and foremost, and in keeping with the requirements of Environmentally Sound Life Cycle Management it is essential that the ULAB are sourced from a reputable dealer that is environmentally sound. Visits to suppliers are essential in this respect.*
- *ULAB should be broken mechanically using a suitably safe and approved saw or crusher. It is totally unacceptable for ULAB to be broken by workers using axes and hammers.*
- *Smelting operations must be enclosed and furnaces must have safe working systems, such as burner failure detection and so on, and adequate hygiene ventilation to keep the work areas free of lead dust and fume.*
- *Finally, it is essential that the working environment is kept clean, that is, free of Lead dust and any lead bearing waste of by products and that all places of work are tidy and free of safety hazards.*

Practical Application of the Benchmarking Tool

When using the Assessment Tool in the field the following steps should be taken:

- ✓ *Complete the relevant section or sections of the Assessment Form for the Assignment by answering the questions in column one of the Form.*
- ✓ *Identify the Key Benchmarks for ULAB Collection, Temporary Storage, Packaging, Transport and Reception*
- ✓ *Determine whether the inspection showed compliance with the key Benchmarks or not and circle the appropriate response. The green boxes indicate “Good” or “Best Practice” and if all the circles are on green boxes, then the recycling plant is likely to be environmentally sound, safe and hygienic.*
- ✓ *Repeat the process for every question and each section of the form.*
- ✓ *Prepare a series of recommendations to implement any improvements, necessary for full compliance.*

Always think in a pro-active manner to resolve a non-conformance.

Use of the Benchmarking Tool

The Benchmarking Assessment Tool has been applied and field tested in India, Costa Rica, China, Kenya and Ghana.

At the instigation of the India Lead Zinc Development Association and in conjunction with Pure Earth, the Benchmarking Assessment Tool was used in a Pilot exercise to resolve a local Lead exposure issue in Tamil Nadu involving the Tamil Nadu State Pollution Control Board and a ULAB recycling plant.

There was full cooperation between the Regional Pollution Control Board and the Company.

To test the ease of use of the Assessment Tool, the minimum amount of instruction about completing the form was given.

The plant inspection then commenced with each member of the Inspection Team observing the recycling operation and circling the appropriate boxes in each section of the form.

Every aspect of the operation was inspected and when completed participants returned to Chennai to review the finding of the Assessment.

In Chennai the participants from the Company, the State Pollution Control Board and the Blacksmith Institute analysed the Assessment Forms in two separate groups in order to compare outcomes and further test the application process.

The Outcome

The discussions were focused, constructive and non-confrontational. The outcomes in the form of recommendations fall into three categories:

- Short Term improvements – No cost and can be implemented immediately
- Short Term – Low cost of up to US\$ 2,000
- Long Term – Where major Capital Investment up to US\$ 1 M is required.

In total, taking the composite of all the participants, there were:

- 12 Short Term Recommendations at no cost that could be implemented immediately

- 9 Short Term recommendations for improvements at a cost of up to US\$ 2,000
- And 4 Long Term recommendations, where major Capital Investment of up to US\$ 1 M is required

The outcomes of this Pilot Exercise formed the basis for a constructive dialogue between the Tamil Nadu State Pollution Control Board and the Company.

Costa Rica

The Benchmarking Assessment Tool has also been used recently at a smelter in Costa Rica at the request of the Government and in conjunction with the Basel Convention Regional Centre for Central America and Mexico.

Following the same process as in India the plant inspection provided sufficient information for the Assessment Tool to Benchmark the likely environmental performance of the smelter.

China

In China the Benchmarking Assessment Tool (BAT) is being applied in a pilot scheme at the request of the China Non-ferrous Metals Industry Association (CNIA) at one of the Chunxing Group Smelters to ascertain whether the Tool could be used to encourage the Government to focus more on sound ULAB recovery and recycling procedures and processes rather than simply capacity and location or rather proximity to populations.

Benchmarks for ULAB Recycling - Conclusions

The following conclusions were made from these three exercises in the use of the Benchmarking Assessment Tool:

- ✓ The Tool is easy to use and provides a rapid assessment of an operation.
- ✓ In the three Pilot exercises, all the major problems were identified, and the companies agreed to make the necessary improvements to comply with the Benchmarks.
- ✓ The process was qualitative, examining the technologies employed, the working practices and the safety procedures.
- ✓ Because the focus was on the operation and the methodologies, the discussions were constructive and not confrontational.

- ✓ Whilst there is no substitute for accurate data to substantiate Good Practice, collating all the data is time consuming, it is often expensive, but there is every reason to believe that the Benchmarking Assessment Tool for the recycling of ULAB could be a cost effective useful indicator of Environmentally Sound Management, Safe Working and good Occupational Health.

The Benchmarking Tool for the Recovery and Recycling of ULAB

The Benchmarking Form is easy to use and is in the form of a questionnaire.

It was designed this way to ensure the questions provide a consistent approach to each assessment, irrespective of the location or the Assessor. It also means that the Benchmarking Assessment can be made without being an expert in the Basel Technical Guidelines or the Best Practice for ULAB recovery and recycling.

The questions are also designed so that conformance with good practice or non-conformance can be identified easily depending on whether the ticks are in the green zones.

The Benchmarking Tool is suitable for the Assessment of Environmental Performance of any phase in the Life Cycle of the Lead Acid Battery from the Mining of Lead Bearing Ore, through Smelting, Lead Refining, Battery Manufacture, Retailing, Used Lead Acid Battery (ULAB) Recovery and Recycling.

Completing the Benchmarking Form

To complete that Benchmarking Form, start with the first Section and enter information about the location, the business and so on.

It is important to record the contact details so that any queries can be followed up.

Section 1. General Information

Section 1 contains information about the company, contact details for the organization, the company representative and the assessor.

Practical Application of the Benchmarking Tool

In each section of the form:

- ✓ *Identify the Key Benchmarks for the appropriate phase of the life cycle, that is, ULAB Collection, Temporary Storage, Packaging, Transport and Reception or Recycling.*
- ✓ *Determine whether the inspection showed compliance with the key Benchmarks or not and circle the appropriate response. The green boxes indicate “Good” or “Best Practice” and if all the circles are on green boxes, then it is likely that the recycling plant will be environmentally sound, safe and hygienic. But please note that the assessment is qualitative and so it is important to follow up with monitoring, sampling and quantitative testing.*
- ✓ *Repeat the process for every question and each section of the form.*

Section 2 – ULAB Collection and Supply Points

Ideally, regulators should visit and inspect ULAB collection centres, car scrap yards, auto and battery retailers, but, it may only be possible to visit a Lead smelter, in which case the regulator should inspect the ULAB reception area and ascertain what type of ULAB are being collected and by whom.

Secondly, it is very important to find out if the ULAB are drained of electrolyte prior to delivery to the smelter or are they being delivered complete with acid.

The ULAB should be inspected to ensure they are not leaking and if any are leaking, the regulator should ascertain if they are transported in a separate plastic leak proof container or not.

In many countries, ULAB collectors and retailers earn extra income by identifying used batteries that are discarded, but just need recharging. So, by testing all ULAB they can select those that can be recharged and sold as a recharged battery. This is perfectly legitimate and maximizes the life of the battery.

Under cover storage is preferred because there is less risk to the environment if a battery is leaking.

Finally, the regulator should ascertain the method of transport and determine how the ULAB are packaged for delivery to the smelter. Vehicles transporting ULAB should display a hazard warning sign consistent with local or national legislation and the ULAB should be shrink wrapped and any leaking ULAB should be in a separate leak proof container.

Section 3 – Environmental Status

First it is important to know which local or national government authority is responsible for issuing operating licences, and remember sometimes it is more than one ministry, such as the environment agency and the health ministry.

It is also important to know how far the smelter is from populations and if the smelter is located in a designated industrial zone.

The regulator needs to find out what happens to any site process effluent. Ideally no process effluent should be discharged from the site, but if it is, then it is important to check on the treatment process if there is an effluent treatment plant. In this way the regulator can ascertain what happens to the ULAB electrolyte, whether it is discharged without treatment or collected and processed.

The next item on the check-list is the emission control system and it is imperative to find out what happens to the dust collected in the filter plant or baghouse.

It is important to check the control systems for the containment of sulfur dioxide, produced from the sulfuric acid residues in the ULAB. Adding iron to the furnace charge material will capture up to 95% of the sulfur in a rotary furnace, but blast furnaces need a scrubber unit to remove the sulfur dioxide.

Moving on through the check list, the next issue is to determine what happens to the furnace residues or “slag”. Lead furnace slags can be toxic, and some are water soluble, but they can be treated and rendered “inert” and even converted into bricks and tiles.

Finally, the regulator should inspect the site to ascertain whether it is clean, tidy and dust free.

Section 4 – Occupational Lead Exposure

It is important for regulators to bear in mind when considering the Benchmarks for Occupational Lead Exposure that they examine the organization's policies and procedures that monitor occupational health and reduce and/or control the levels of Lead exposure.

So, the first task is to ascertain whether there is a hygiene or a respirator policy.

Secondly, and this is the most important task, to observe the operating personnel at work and ascertain if they are wearing their respirators correctly and all the time in exposed areas, such as the smelter or the refining floor.

Regulators should inquire if there is a medical officer and/or an occupational nursing officer appointed by the company to monitor occupational health and counsel employees if necessary.

The medical staff do not have to be full time employees but can be part time as long as the visits to the operations are regular and within a reasonable time frame. Furthermore, it is essential that employers made their employees and anyone else on site aware not only of the potential risk associated with Lead exposure, but also the personal precautions that need to be taken to reduce or minimize the risks.

The regulators should find out if the operating personnel are issued with works clothing and if so how often is it changed and washed. They should also find out whether the canteen is segregated from the Lead smelting and production areas. It is not sufficient to be told that eating on site is not permitted and operating staff are expected to turn up for work having already eaten, because if they do not eat before or during working hours, the risk of lead ingestion increases.

Finally, the wash room and shower block must be inspected, if there is one, and the regulator needs to determine whether employees working in the exposed areas, particularly smelting, shower and change into clean clothes to go home.

Section 5 - Safety

The Company's approach to Safety is the subject of Section 5 and it is essential to find out whether there is a written and credible Safety Policy made available to employees on notice boards or a handbook or electronically via the Internet.

The regulator should find out if there are regular safety inspections or audits or both. He or she should determine if every employee, contractor and visitor has received an appropriate safety induction. Companies adopting best practice will induct every person visiting or working at the site.

Next, the assessor needs to find out if risk assessments have been carried out for every job or task on site. If an operation has ISO 9001, then every task associated with the certificate will have a risk assessment but bear in mind that ISO 9001 does not mean that every aspect of the operation is included, because the ISO 9001 can be for one part of the process, such as casting.

The next matter for the assessor is to confirm whether there is an accident book and look to see if all accidents are not only recorded, but also investigated and by whom. Ideally, all accidents should be investigated by team that includes a safety specialist, a line manager and a worker's representative.

It is very important that any item of plant or equipment is isolated when undergoing any form of maintenance, modification or cleaning. Not only that, it **MUST** be locked out of the electrical and energy supply system and there should be a written authorisation for work to be undertaken.

Finally, an inspection of the fire precautions at the premises must be made. Ideally there should be foam extinguishers and sand buckets. The fire extinguishers must be current, and all should be accessible to the workers.

Practical Application of the Benchmarking Tool

Once the form is completed, the assessor must study the notes made on the BAT form and;

- ✓ *Prepare a series of recommendations that will either endorse the procedures and practices at the plant, which would be for full compliance and every green box circled*

and/ or

- ✓ *A list of improvements required to achieve conformance.*

Always think in a pro-active manner to resolve a non-conformance.

The Outcomes

The outcomes in the form of recommendations will normally fall into three categories:

- Short Term improvements – No cost and can be implemented immediately
- Short Term – Low cost of up to US\$ 2,000
- Long Term – Where major Capital Investment up to US\$ 1 M is required.

No.

Benchmarking Form Used Lead Acid Battery Recovery and Recycling

1.0 General Information

Company Name	
Location	
Business	
Date	
Company Address	
Company Representative	
Job Title	
Phone number	
E-mail address	
Internet – Company Web Site Address	
Operational area (Hectares) (approximately)	
Benchmarking Assessor	
Phone number	
E-mail address	
Number of employees	
Age and service profiles	

2. ULAB Collection and Supply Points – Retailers, Garages, Repair Shops, Scrap Dealers, Battery Service and Collection Centres

No.		A	B	C	D
1	What Used Lead Acid Batteries (ULAB) are being collected?	Car	Motorcycle	UPS/Security	Industrial
2	How are ULAB collected?	Citizens	Retailers	Garages	Scrap Dealer
3	How are the ULAB delivered? Drained of Acid or complete with Acid?	Drained	Most drained	A few drained	Complete
4	How are the ULAB sorted?	Size	Plastic case	Automotive	Industrial
5	Are ULAB that leak separated and packed in plastic containers?	No	Drained first	Sometimes	Always
6	What happens to the ULAB collected?	Reconditioned	Sold	Tested and recharged	Packaged & shipped
7	How are ULAB stored while waiting for dispatch to the recycler?	In the open	Packaged in the open	Under cover	Packaged & under cover
8	How are ULAB collected transported to the recycling plant?	Bicycle/cart	Open truck	Closed truck/van	Licensed truck/van
9	How are the ULAB packed onto or into the vehicle for transport to the recycling plant?	Loose	Loose and upright	Palletized & wrapped	As C with any leaking ULAB in a leak proof container.

3. Environmental Status

No.		A	B	C	D
1	What agencies issue your environmental and operating licenses?	Health	Environment	Business	Other
2	How close is the general population to the Recycling Plant?	Next to the Plant	1 kilometre	5 Kilometres	Industrial Zone
3	Is process effluent discharged from the site?	Always and untreated	Sometimes untreated	After treatment	Never
4	What happens to the battery acid drained from the ULAB?	Discharged	Treated and discharged	Collected, treated and used in the process	Collected to produce Gypsum
5	How are furnace and refining emissions from the plant controlled?	No control	Furnace is ventilated to a baghouse	All processes are ventilated to a Baghouse	As C with all dust recycled
6	If your plant is using a Blast Furnace – Do you have a Scrubber Unit?	No	Yes		
7	If your plant is using a Rotary Furnace – Do you add iron to the charge Material?	No	Yes		
8	What do you do with your furnace residues?	Dispose of in a local tip	Treat and dispose of in a secure landfill	Treated and sold for hard core	Treated and used to make bricks/tiles
9	Is the site clean, tidy and free of dust, slag and acid residues?	No	Dust and Slag only	Acid residues only	Yes

4. Occupational Lead Exposure

No.		A	B	C	D
1	Is there a hygiene and respirator policy?	No	Respirator only	Hygiene only	Yes
2	Are respirators worn by all personnel in the operating areas	No	Some do	Only operating personnel	All personnel
3	Is there a Medical Officer and/or Occupational Nurse appointed to check the health of the workers?	No	On request	Nurse only	Yes
4	Are the occupational Lead in Blood levels checked?	Never	Annually	Twice annually	Every quarter
5	Do you communicate health risks to employees?	Never	If asked	Induction	Regularly
6	Are operating personnel issued with works clothing?	No	Overalls	Overalls, hat	Overalls, hat, boots & gloves
7	If so, how often are the clothes washed and changed?	Never	Every month	Every week	Every shift
8	Are eating and process areas segregated?	No	Eating on site is not permitted	Yes, but not ventilated	Yes with HEPA Air conditioning
9	Are there showers on site for use by the operators?	No, but there is a washroom	Yes, one shower	Yes, but it is not compulsory	Yes and it is compulsory

5. Safety

No.		A	B	C	D
1	Is there a Safety Policy published and available for inspection?	No	In a safety folder	On display on site	On display and on the web site
2	Are there regular Safety Inspections and Audits?	No	Sometimes after an accident	Inspections but no audits	annually
3	Does every visitor, employee & contractor undergo a Safety Induction?	No	Employees only	Visitors and Contractors only	Everybody
4	Have risk assessments been carried out for each operation?	No	Only for the EIA	Only for ISO 9001	Yes
5	Is there a record of every accident on site?	No	There is an accident book	Some accidents are recorded	Yes in the accident book
6	Is every accident investigated?	No	Yes, by the plant manager	Yes, by the insurance company	Yes, by a joint management and worker team
7	Is there a Permit to Work and Lock-Off system for maintenance?	No	Permit to work only	Lock-off only	Yes and with keys and locks
8	What Fire Precautions and Procedures are in place?	None	There are fire extinguishers	There are sand buckets	There are extinguishers and sand buckets
9	Does the Company have Liability Insurance for Accidents and Incidents?	No	Third Party, Fire and Theft only	Accidents or Incidents only	Full cover for accidents and incidents

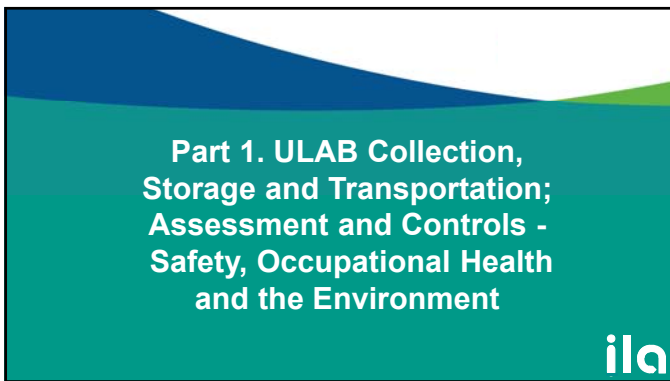

Barriers to the ESM of ULAB Recycling...

Developing Countries and Nations in Transition

- ⚠ ESM of ULAB Recycling is not at the Top of the Political Agenda
- ⚠ Informal Recyclers and Traders (Export) Offer Top Prices for ULAB
- ⚠ Transport Costs are relatively high and journey times can be long
- ⚠ Informal Recyclers often employ illegal migrant workers
- ⚠ Informal Recycling costs are low due to the lack of environmental controls
- ⚠ Environmental Regulators do not appreciate Informal Recycling threats
- ⚠ Technical/Engineering Base – essential for plant operations – is low
- ⚠ Unemployment is high and workers are easily replaced



ESM Matrix for Countries in Transition...

Activity	Process	ESM
ULAB Collection	Closed Loop	ULAB Undrained
Transportation	Plastic Container	Leak Proof
Temporary Storage	Under Cover	No Leakage
ULAB Breaking	Saw/Hammer Mill	Not Manual
Electrolyte	Neutralisation	No Discharge
Recycling	Ventilated Smelting	Emission Control
By- Products	Inert Products	No Hazardous Waste



ULAB Recycling: Key Processes

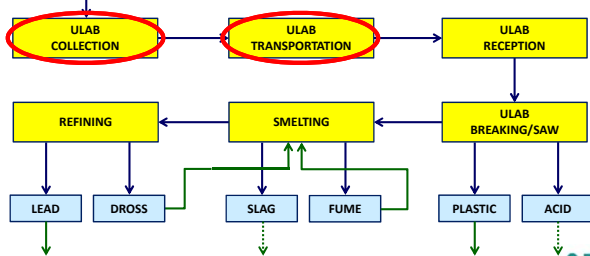

ULAB Collection: ULAB Safety and Health Risks

ULAB Contains	Classification	Pathway	PPE
Lead and Acid		Ingestion Spill and Splash	
Lead – It's Heavy			



ULAB Collection: ULAB Safety and Health Risks

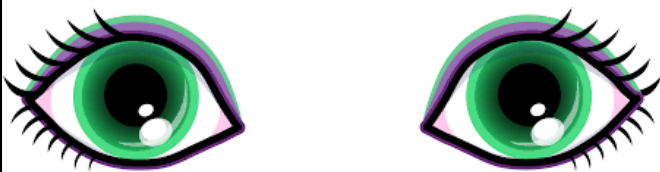

What About Your Eyes?



ULAB Collection: ULAB Safety and Health Risks



Always have an Eye Wash Station – or Eye Wash Solution



ULAB Collection: ULAB Safety and Health Risks



What About Your Feet?



ULAB Collection: ULAB Safety and Health Risks

Wear Safety Footwear



Lead Acid Batteries can be heavy and weigh up to 1 mt



ULAB Collection: ULAB Safety and Health Risks



Lead Batteries can be heavy and weigh up to 1 mt



ULAB Collection: ULAB Safety and Health Risks

BE CAREFUL



BEND KNEES WHEN LIFTING



Lead Acid Batteries can be heavy and weigh up to 1 mt



ULAB Packaging and Storage: Risks – Acid Leakage



Sort by size and stack evenly



ULAB Packaging and Storage: Risks – Acid Leakage



Sort by size and stack evenly



ULAB Packaging and Storage: Risks – Acid Leakage

Battery design is key to risk reduction 

ULAB Collection: Environmental Risks – Acid Dumping

How much Sulfuric Acid is Dumped?

For Every:

20,000 mt of Drained ULAB = 12,000 mt Refined Lead
 = 2,600 mt of Acid

Do Not Drain the Battery Electrolyte! 

ULAB Collection: Environmental Risks – Acid Dumping

Battery Electrolyte is Sulfuric Acid and it is:

- ❖ Classified as a Hazardous Waste
- ❖ Irritant to Skin and Internal Organs
- ❖ If splashed in the Face - Can Cause Blindness
- ❖ Carcinogen
- ❖ Corrosive – will dissolve concrete

Do Not Drain the Battery Electrolyte! 

ULAB Packaging and Storage: Risks – Acid Leakage

Prevent Movement - Wrap the ULAB Tightly 

ULAB Packaging and Storage: Risks – Acid Leakage

Sort by size and stack evenly 

ULAB Collecton: ULAB Environmental Risks

Leaking ULAB Harms Eco-Systems 

Transportation: UN Certified Leak Proof Container



- Benefits
- ✓ UN Certified
 - ✓ Use in Any Vehicle
 - ✓ Lightweight
 - ✓ Fork Truck Friendly
 - ✓ Stackable



Transportation: UN Certified Leak Proof Container



- Benefits
- ✓ UN Certified
 - ✓ Use in Any Vehicle
 - ✓ Lightweight
 - ✓ Fork Truck Friendly
 - ✓ Stackable
 - ✓ Reusable



Transportation: UN Certified Leak Proof Container



- Benefits
- ✓ UN Certified
 - ✓ Use in Any Vehicle
 - ✓ Lightweight
 - ✓ Fork Truck Friendly
 - ✓ Stackable
 - ✓ Reusable



Temporary Storage: Outdoors is not ideal...



Open Ground – Liable to Acid Contamination



Temporary Storage: Undercover is Ideal...



Temporary Storage: Undercover is Ideal...

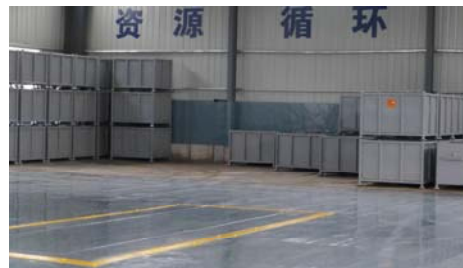

Resin Coated Impermeable Floor Covering



Temporary Storage: Undercover is Ideal...



Use Steel Racking to Store Palletized ULAB



Temporary Storage: Install a Sump and Pump



Capture Any Acid Spillage



Temporary Storage: Weather Proof Container



Pictures courtesy of UNISEG Pallets



ULAB Transportation: Dedicated Licensed Vehicle



Closed Truck with Hazchem Decals



Closed Loop and Reverse Logistics...



Most Effective Way to Control ULAB Recycling

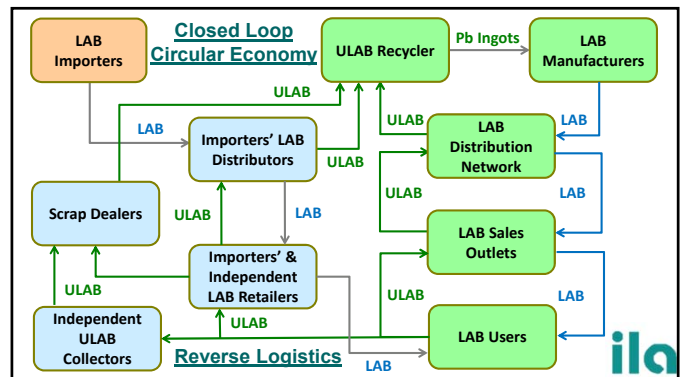

Part 2. ULAB Breaking: Risk Assessment and Controls - Safety, Occupational Health and the Environment

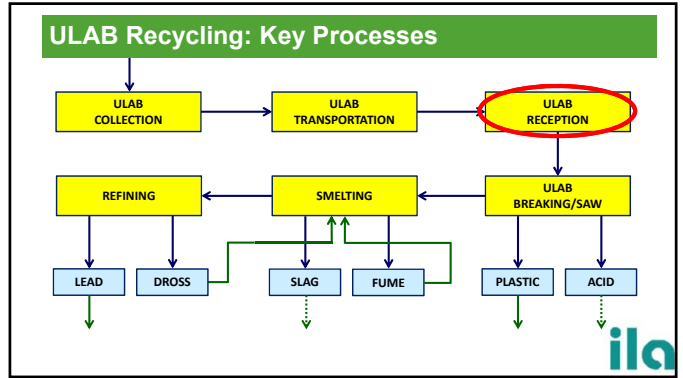
ULAB Reception: ULAB Safety and Health Risks

ULAB Contains	Classification	Pathway	PPE
Metallic Lead		Ingestion	
Lead Oxides & Sulfates		Ingestion	
Dilute Sulfuric Acid		Spill and Splash	
Separators	Safe – if clean	Ingestion	
Weight		Hands and Feet	



ULAB Reception: ULAB Safety and Health Risks

BE CAREFUL



**BEND
KNEES WHEN
LIFTING**

CAUTION



**TWO PERSON
LIFT
REQUIRED**

Lead Acid Batteries can be heavy and weigh up to 1 mt



ULAB Reception: Select and Recharge...

But in many cases a ULAB can be recharged



and sold as a recharged battery providing additional income

Sell the Recharged Batteries:



ULAB Reception: Recharge and Sell...



Sell the Recharged Batteries:



ULAB Reception: ULAB Safety and Health Risks

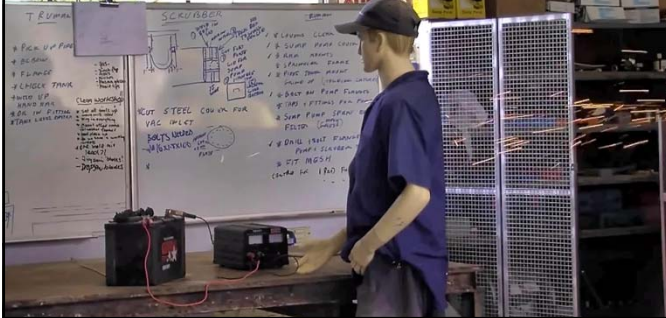

ULAB Reception: ULAB Safety and Health Risks



DANGER
Risk of explosion



No smoking
No naked lights



ULAB Reception: ULAB Environmental Risks



Leaking ULAB will harm the environment – particularly Eco-Systems



Mitigation: UN Certified Leak Proof Container



Benefits

- ✓ UN Certified
- ✓ Use in Any Vehicle
- ✓ Lightweight
- ✓ Fork Truck Friendly
- ✓ Stackable
- ✓ Reusable



ULAB Reception: Inspection and Selection...

Check for Non-Lead Batteries:

Remove Lithium Ion Batteries from the Recycling Process

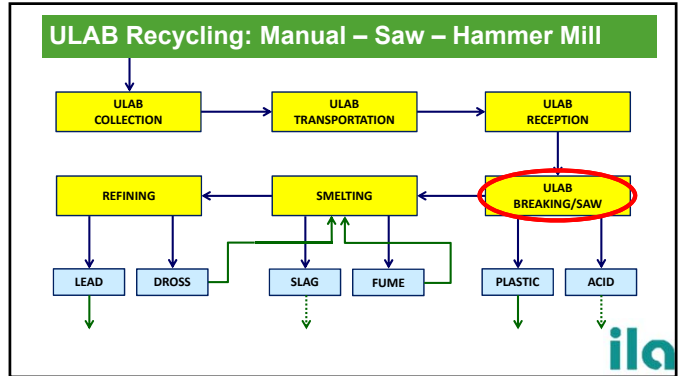

Battery Breaking: Manual Breaking...

Unsafe
Unsound
Unwise

Avoid
Manual
Breaking

Tegal - Indonesia

Battery Breaking: Battery Saw...

Electrolyte must be drained to the ETP prior to entering the saw

Saw Blades must be adjusted to the height of the ULAB

Video courtesy of EcoGlobal Inc. and Gravita India

ULAB Battery Saw: Safety and Health Risks

ULAB Contains	Classification	Pathway	PPE
Metallic Lead		Ingestion	
Lead Oxides & Sulfates		Ingestion Inhalation	
Dilute Sulfuric Acid		Spill and Splash	
Acid Mist		Ingestion Inhalation	
Noise		Ears	

ULAB Reception: ULAB Safety and Health Risks

Wear Safety Footwear

Lead Acid Batteries can be heavy and weigh up to 1 mt

Battery Breaking: Hammer Mill...



Electrolyte must not be drained from the ULAB prior to entering the mill



pb metals

Video courtesy of Pb Metals – Costa Rica



Battery Breaking: Hammer Mill...



Grid Metallics

pb metals

Video courtesy of Pb Metals – Costa Rica



Battery Breaking: Hammer Mill...













Plastic Separation

pb metals

Video courtesy of Pb Metals – Costa Rica



ULAB Hammer Mill: Safety and Health Risks

ULAB Contains	Classification	Pathway	PPE
Metallic Lead		Ingestion	
Lead Oxides & Sulfates		Ingestion Inhalation	
Dilute Sulfuric Acid		Spill and Splash	
Acid Mist		Ingestion Inhalation	
Noise		Ears	

ULAB Hammer Mill: Safety and Health Risks

NO OPEN TOE SHOES BEYOND THIS POINT

Wear Safety Footwear



Lead Acid Batteries can be heavy and weigh up to 1 mt



ULAB Hammer Mill: Li-ion Safety Risk - Explosion



7/8/2014 2:19:21 AM

Do Not Process Li-ion Batteries through a Breaker



Environmental Risk: Battery Electrolyte

ULAB Electrolyte is dilute Sulfuric Acid



Corrosive and Destroys Eco - Systems

Picture courtesy of Pure Earth - India



Battery Electrolyte: Neutralisation – No discharge



Effluent Treatment – Closed Loop



Effluent Treatment: Battery Electrolyte

Electrolyte must be treated In an ETP to produce a saleable by-product



Recycling symbol: Eco - friendly process without any discharges

Picture courtesy of pb metals, Costa Rica



Coping with Monsoon and Typhoon Conditions...

Process tanks must be elevated



Picture courtesy of Wirtz Manufacturing Inc.



Battery Electrolyte Saleable By-Products...

ETP: Electrolyte/Acid Neutralization – Add +

$$H_2SO_4 + 2NaOH = Na_2SO_4 + 2H_2O$$

$$H_2SO_4 + Na_2CO_3 = Na_2SO_4 + H_2O + CO_2$$

$$H_2SO_4 + Ca(OH)_2 = CaSO_4 \cdot 2 H_2O$$

$$H_2SO_4 + (NH_4)_2CO_3 = (NH_4)_2SO_4 + CO_2 + H_2O$$

By-Product Sales Options...

Sodium Sulfate	• Glass Making • Paper Making
Gypsum	• Cement Industry • Building Materials
Ammonium Sulfate	• Fertilizer



Treated Effluent Options...

Coolant for Lead Casting Damping Down

Effluent Treatment Plant: Safety and Health Risks

ULAB Contains	Classification	Pathway	PPE
Dilute Sulfuric Acid		Spill & Splash	

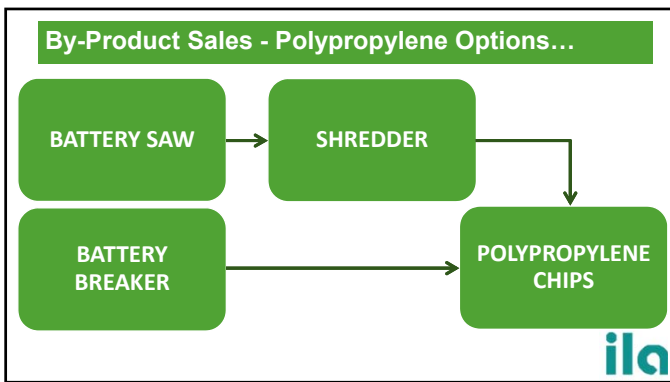

By-Product Sales - Polypropylene Options...

- Polypropylene Chips • USD \$ 500 / mt
- Polypropylene Pellets** • USD \$ 800 / mt

Part 3. Lead Smelting Operations: Risk Assessment and Controls - Safety, Occupational Health and the Environment

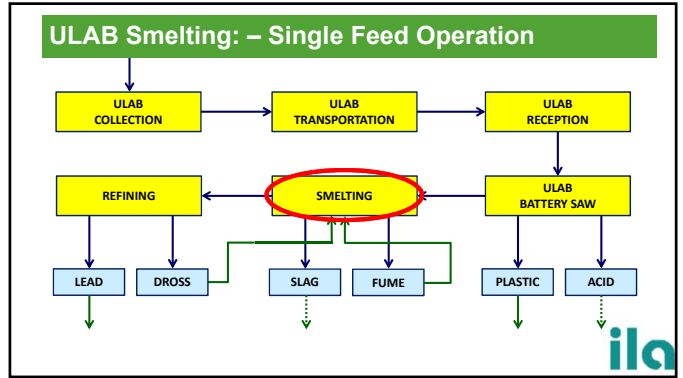
Smelting...

Segregation of Battery Components:

- ❖ Grid Metallics
- ❖ Battery Paste

Processing:

One or Two Furnace Operation?

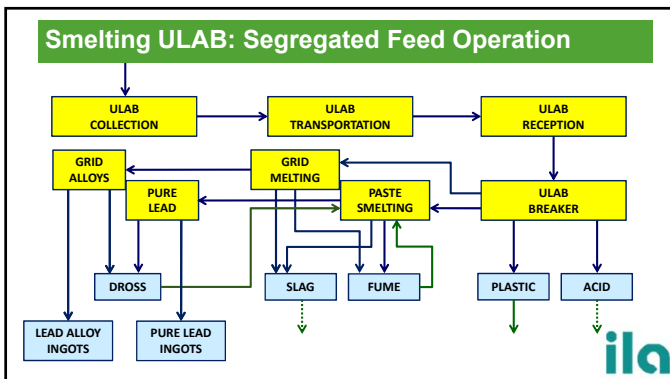
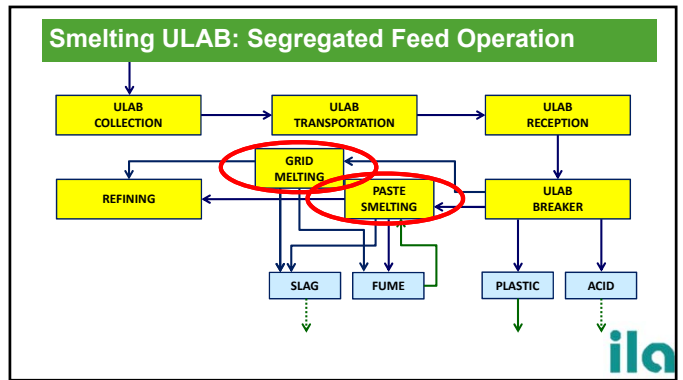
- ### Smelting ULAB: Segregated Feed Operation
- Environmental and Cost Benefits
- ✓ Melting the Grid Metallics uses ~ 70% less energy than smelting
 - ✓ Melting Grids does not require fluxes, reducing agents & reagents
 - ✓ Refining Grid bullion to alloys saves energy & alloy metal use
 - ✓ Refining Paste bullion to pure Lead uses less energy and reagents
 - ✓ Twin furnace operation offers flexibility to planned maintenance
 - ✓ Twin furnace operation provides greater continuity of production
 - ✓ O & M savings approximately 13% over single furnace operation
- 

Smelting: Energy Efficient Furnace Operation



Rotary Furnace - Pb Metals – Costa Rica 

Smelting: Energy Efficient Furnace Operation

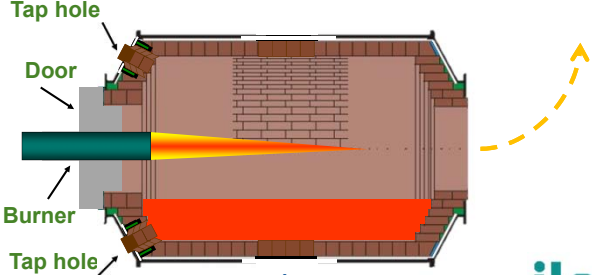

Front Mounted Burner 

Smelting: Energy Efficient Furnace Operation

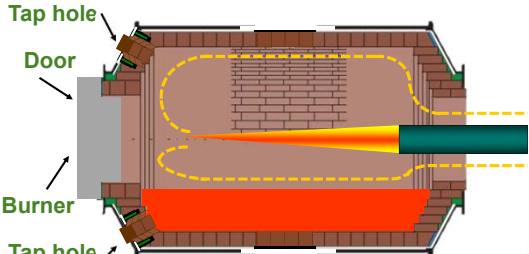

Rear Mounted Burner - Reverberatory Furnace 

Smelting: Energy Efficient Furnace Operation

Environmental and Cost Benefits

- ✓ Double Pass through the furnace makes best use of energy
- ✓ Cycle times are reduced and with it energy consumption
- ✓ Reduced cycle times results in increased daily production
- ✓ Reduced energy consumption means lower GHG emissions
- ✓ Reduced energy consumption means lower fuel bills
- ✓ Rear mounted burner reduced risk of damage during charging

Rear Mounted Burner - Reverberatory Furnace 

Smelting: Environmental Threat : Fume - Capture?

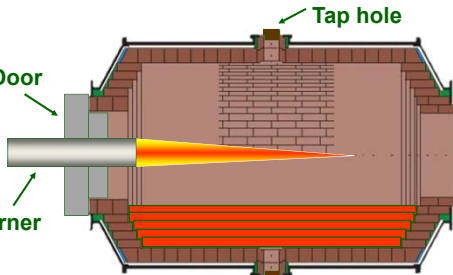

Centre Tap Hole 

Smelting: Fume – Capture by Encapsulation



EcoGlobal – The Philippines 

Smelting: Fume – Capture by Encapsulation



ECOGLOBAL

EcoGlobal – The Philippines



Smelting: Environmental Threat : Fume - Capture?

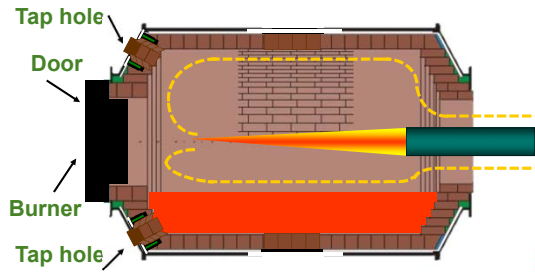

Smelting: Environmental Threat : Fume - Capture?

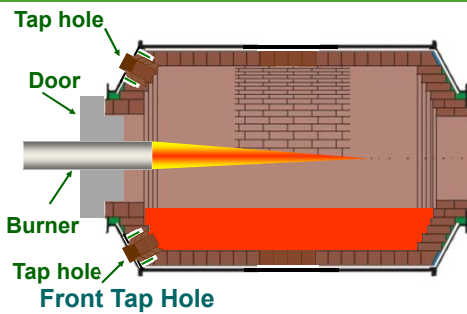

Smelting: Environmental Threat : Fume Capture



Ventilation Hooding - Front Tapping Rotary Furnace



Smelting: Environmental Threat : Fume Capture

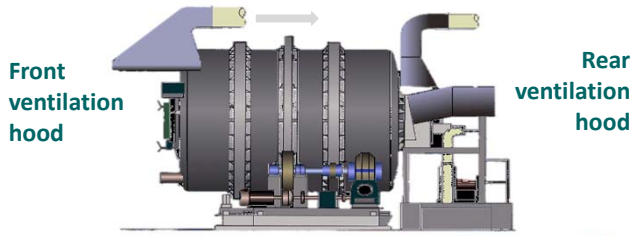

Rotary Furnace Ventilation



Smelting: Environmental Threat : Fume Capture



Front Tap Hole



Smelting: Occupational Health Threat : Fume Capture??

Occupational Health Threats from Lead Dusts and Fume

- ⚠ Exposure, inhalation and digestion – leads to elevated Pb in Blood
- ⚠ Elevated Exposure – Can lead to:
 - Tiredness, irritability, constipation, internal organ damage
 - Abdominal pain, Constipation, Joint and Muscle pain,
 - Headache, Decline in Cognitive Reasoning
- ⚠ In extreme cases Acute Exposure - Death
- ⚠ Uncontrolled emissions leads to population exposure

Why Dust and Fume must be captured. 

Smelting: Occupational Health Threat : Fume Capture??

Particle Size for Lead Dusts and Fume

Lead Fume: 0.1 to 0.7 microns
Smelter dust: up to 500 microns

Respiratory Protection: N95 Dust Mask filters -
✓ 95% of all particles over 0.3 microns



Why Dust and Fume must be captured. 

Smelting: Occupational Health Threat : Fume Capture??

Particle Size for Lead Dusts and Fume

Lead Fume: 0.1 to 0.7 microns
Smelter dust: up to 500 microns

INVISIBLE TO THE EYE					VISIBLE TO THE EYE				
LEAD SMELTER DUST/FUME									
0.001	0.005	0.01	0.05	0.1	0.5	1	5	10	50
PARTICLE SIZE IN MICRONS									



Smelting: Environmental Threat : Fume Capture??



Is there Extraction Ventilation? 

Smelting: Occupational Health Threat : Emissions??



Emission Controls are Essential 

Smelting: Fume Capture - Control Measure - Filtration

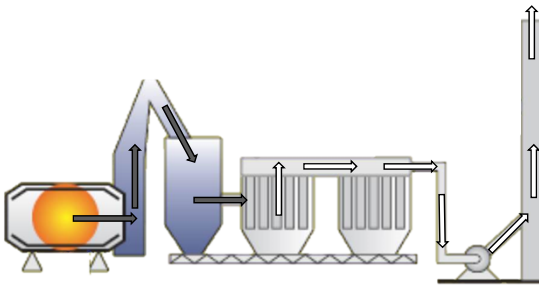



Smelting: Fume Capture - Control Measure - Filtration



Typically Filter Bags Capture Dust to 25 microns **ila**

Smelting: Fume Capture - Control Measure - Filtration

Long Ventilation Ducts are Required for Cooling



An Air Bleed is not Permitted for cooling

Off-Gas Cooling - Vital to Form Dust > 25 microns **ila**

Smelting: Fume Capture - Control Measure - Filtration

Capture the Baghouse Dust in a Steel Drum



Seal the Drum and Charge to the Furnace

Zhejiang Changxing Jintaiyang Power Co., Ltd **ila**

Smelting: Fume and Dust Capture – Financial Risk

Informal Operations:

Losses ~ 2%

24,000 mt of ULAB =

~ 14,100 mt of Lead +

~ 300 mt losses

= USD \$ ~ 600,000

Installing and Operating a Baghouse - Economical **ila**



Smelting: Environmental Threat: SO₂ Emissions



SO₂ Contributes to Acid Rain **ila**

Smelting: Occupational Health Threat: SO₂ Emissions



SO₂ is Toxic – As toxic as Cyanide Gas **ila**

Smelting: SO₂ Control Measures – De-Sulfurization

Three Options:

- Before Smelting
- During Smelting
- After Smelting

Paste De-Sulfurization



Smelting: SO₂ Control Measures – De-Sulfurization

Two Options: 1

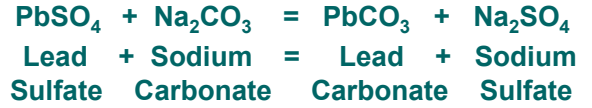

Other compounds: Pb₃(CO₃)₂(OH)₂, NaPb₂(CO₃)₂OH

Paste De-Sulfurization



Smelting: SO₂ Control Measures – By-Products



Kraft Paper Making Process



Smelting: SO₂ Control Measures – De-Sulfurization

Two Options: 2

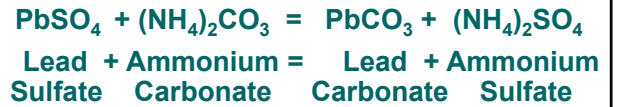

Paste De-Sulfurization



Smelting: SO₂ Control Measures – De-Sulfurization

Three Options:

- Before Smelting
- During Smelting
- After Smelting

Paste De-Sulfurization



Smelting: SO₂ Control Measures – De-Sulfurization

Add Scrap
Iron
to the
Furnace
Charge



95% of
Sulfur is
Removed
By Iron
Addition

Paste De-Sulfurization



Smelting: SO₂ Control Measures – De-Sulfurization

Metallurgical Equations for the capture of Sulfur:



Erdite Slag with the formula NaFeS₂

Paste De-Sulfurization



Smelting: SO₂ Control Measures – De-Sulfurization

Metallurgical Equations - Sulfur Dioxide Production

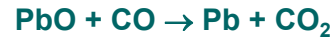

Paste De-Sulfurization



Smelting: SO₂ Control Measures – De-Sulfurization

Three Options:

- Before Smelting
- During Smelting
- **After Smelting**



Smelting: SO₂ Control Measures – De-Sulfurization

To Atmosphere



Smelting: SO₂ Control Measures – De-Sulfurization



Scrubbing Tower



Smelting: Population Threat: Dioxins and Furans

Occupational & Population Health Threats:

- ⚠ Toxic Persistent Organic Pollutant
- ⚠ Adverse health impacts to immune system & hormones
- ⚠ Impairs development
- ⚠ Can cause liver damage and liver damage
- ⚠ Interferes with the Heme metabolism and thyroid function
- ⚠ Carcinogenic



ULAB Recycling: Environmental Threat - Slag...

Environmental and Health Threats:

- ⚠ Can contain Lead Prills and Lead compounds
- ⚠ Hydrosopic and will break down on exposure to air
- ⚠ Broken down – irritant – eyes, skin and lungs
- ⚠ Broken down – certain toxic compounds are soluble
- ⚠ Toxic

Dump the Slag..... Anywhere?



ULAB Recycling: Environmental Threat - Slag...



Dump the Slag.....Anywhere?



ULAB Recycling: Environmental Threat - Slag...

Dispose at a hazardous Waste Treatment Plant



Problem: Landfill Sites come at a cost



Dump the Slag..... Hazardous Waste Site



Slag... Can be converted to Hexagonal Paving.

Summit Hill



Nepal

Essential to undertake Market Research



Slag... Can be converted to Hexagonal Paving.

Tegal



Indonesia

Hexagonal Paving Slab Machine



Slag... Can be converted to Hexagonal Paving.

Tegal



Indonesia

Hexagonal Paving Slabs



Slag... Can also be converted to Concrete Bricks

Tegal Indonesia



Brick Paver Machine ila

ULAB Battery Smelting: Safety and Health Risks

Smelting Risks	Classification	Pathway	PPE
Lead dusts		Ingestion Inhalation	
Lead Fume		Inhalation	Effective Furnace Extraction Ventilation
Hot Metal and Slag		Body – Spills, Sparks/Splashes	
Noise		Ears	
Baghouse Maintenance		Ingestion Inhalation	

ULAB Battery Smelting: Control Measures



Housekeeping: Dust Free - Clean & Tidy ila

ULAB Battery Smelting: Control Measures



Housekeeping: Damp Down Working Areas ila

ULAB Battery Smelting: Control Measures



 Personal: Always wear the correct PPE ila

ULAB Battery Smelting: Control Measures



Choose disposable dust masks with exhaust valves

Disposable Respirators ila

ULAB Battery Smelting: Control Measures



Most Important!
Use the metal strip to ensure a good fit around the nose

Disposable Respirators



ULAB Battery Smelting: Control Measures



Most Important!
Use full mask and coveralls when working in a Baghouse

Full Face Respirators



ULAB Battery Smelting: Control Measures



Most Important!
Use full mask and coveralls when working in a Baghouse

Full Face Respirators and Coveralls



ULAB Battery Smelting: Control Measures



Most Important!
Use full mask and coveralls when working in a Baghouse

Full Face Respirators and Coveralls



ULAB Battery Smelting: Control Measures

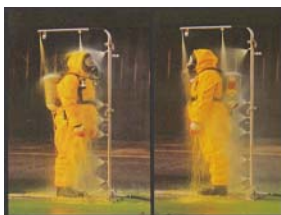

Most Important!
Work done – Shower wearing the Protective Suit and Respirator to remove dust – then remove them

Full Face Respirators and Coveralls



ULAB Battery Smelting: Control Measures

Furnace Operations

Helmet, face visor, boots, respirator, gloves, protective overall or coat



Tapping the Furnace



ULAB Battery Smelting: Control Measures



Clean Work Clothes – Every Day/Shift



ULAB Battery Smelting: Control Measures



Clean Work Clothes – Every Day/Shift



ULAB Battery Smelting: Control Measures

- 1. Segregate home & work clothing in changing rooms
- 2. All personnel to shower at the end of the day/shift
- 3. Only wear home clothes when leaving the plant
- 4. Provide a clean dust free place to eat



ULAB Battery Smelting: Control Measures



Segregated and Clean Changing Rooms



ULAB Battery Smelting: Control Measures

Shower Block



Dong Mai Vietnam

Shower at the End of Every Day/Shift



ULAB Battery Smelting: Control Measures



A Clean Canteen with HEPA Filter



Design for a Changing Room and Canteen

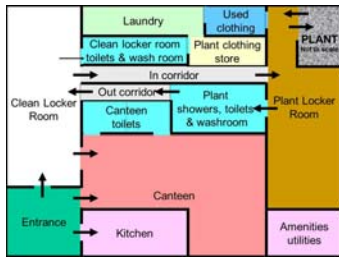

http://www.ila-lead.org/UserFiles/File/guidancenotes/ILA_GN_Changing_Rooms.pdf



ULAB Recycling: What else can we do?

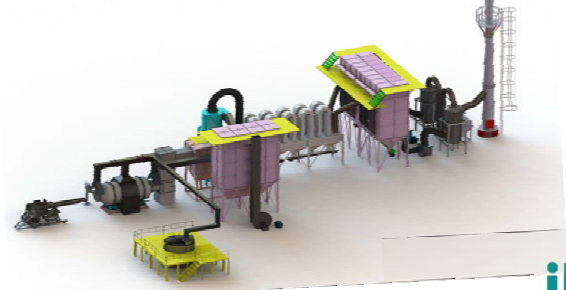

Enclose: Apply Negative Pressure via Baghouse



Why can't we do this?



Install Solar Panels to generate electricity...



Solar Energy – 300 KW



Thank You



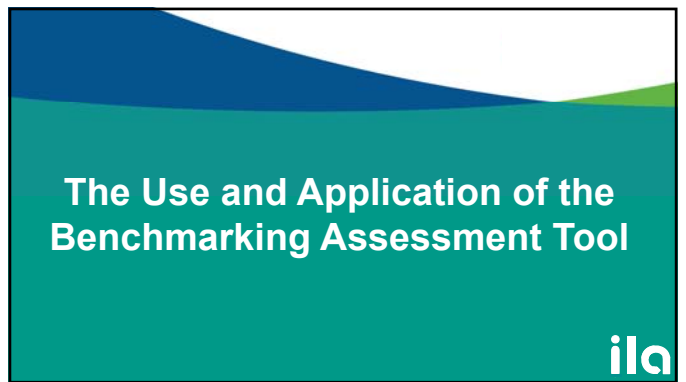

ESM Matrix for ULAB Recycling...

Activity	Process	ESM
ULAB Collection	Closed Loop	ULAB Undrained
Transportation	Plastic Container	Leak Proof
Temporary Storage	Under Cover	No Leakage
ULAB Breaking	Saw/Hammer Mill	Not Manual
Electrolyte	Neutralisation	No Discharge
Recycling	Ventilated Smelting	Emission Control
By- Products	Inert Products	No Hazardous Waste

ila



Assessing ESM

The questions for the regulators are:

- *Can you evaluate performance?*
- *Can you identify problems?*
- *Can you make recommendations to improve the ESM of ULAB?*



Observation and Measurement

Does the regulator just Observe and Measure?



What if the Regulator could identify problems and help to resolve them?



Benchmarking Assessment Tool

- ✓ *Comprehensive and easy to use*



Benchmarking Assessment Tool

These are the only assessment aids required:



A pH paper test kit and an Anemometer



Benchmarking Assessment Tool

- ✓ *Comprehensive and easy to use*
- ✓ *Consistent with the BTG*



Basel Convention

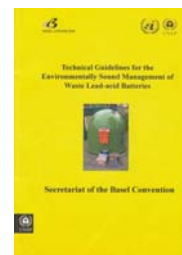

Technical Guidelines



Benchmarking Assessment Tool

- ✓ *Comprehensive and easy to use*
- ✓ *Consistent with the BTG*
- ✓ *In the form of a questionnaire*



Benchmarking Assessment Tool

No.	ULAB Collection and Supply Points	A	B	C	D
1	What Used Lead Acid Batteries (ULAB) are being collected?	Car	Motorcycle	UPS/Security	Industrial
2	How are ULAB collected?	Citizens	Retailers	Garages	Scrap Dealer
3	How are the ULAB delivered? Drained of Acid or complete with Acid?	Drained	Most drained	A few drained	Complete
4	How are the ULAB sorted?	Size	Plastic case	Automotive	Industrial
5	Are ULAB that leak separated and packed in plastic containers?	No	Sometimes	Drained first	Always
6	What happens to the ULAB collected?	Tested and recharged	Reconditioned	Sold	Packaged & shipped
7	How are ULAB stored while waiting for dispatch to the recycler?	In the open	Packaged in the open	Under cover	Packaged & under cover
8	How are ULAB collected transported to the recycling plant?	Bicycle/cart	Open truck	Closed truck/van	Licensed truck/van
9	How are the ULAB packed onto or into the vehicle for transport to the recycling plant?	Loose	Loose and upright	Palletized & wrapped	As C with any leaking ULAB in a leak proof container.

2 of 5 - ULAB Collection and Supply Points



Benchmarking Assessment Tool

- ✓ *Comprehensive and easy to use*
- ✓ *Consistent with the Basel Technical Guidelines*
- ✓ *In the form of a questionnaire*
- ✓ *Identifies Good Practices and Not So Good*



Benchmarking Assessment Tool

No.	ULAB Collection and Supply Points	A	B	C	D
1	What Used Lead Acid Batteries (ULAB) are being collected?	Car	Motorcycle	UPS/Security	Industrial
2	How are ULAB collected?	Citizens	Retailers	Garages	Scrap Dealer
3	How are the ULAB delivered? Drained of Acid or complete with Acid?	Drained	Most drained	A few drained	Complete
4	How are the ULAB sorted?	Size	Plastic case	Automotive	Industrial
5	Are ULAB that leak separated and packed in plastic containers?	No	Sometimes	Drained first	Always
6	What happens to the ULAB collected?	Tested and recharged	Reconditioned	Sold	Packaged & shipped
7	How are ULAB stored while waiting for dispatch to the recycler?	In the open	Packaged in the open	Under cover	Packaged & under cover
8	How are ULAB collected transported to the recycling plant?	Bicycle/cart	Open truck	Closed truck/van	Licensed truck/van
9	How are the ULAB packed onto or into the vehicle for transport to the recycling plant?	Loose	Loose and upright	Palletized & wrapped	As C with any leaking ULAB in a leak proof container.

2 of 5 - ULAB Collection and Supply Points



Benchmarking Assessment Tool

- ✓ *Comprehensive and easy to use*
- ✓ *Consistent with the Basel Technical Guidelines*
- ✓ *In the form of a questionnaire*
- ✓ *Identifies Good Practices and Not So Good*
- ✓ *Applicable to the whole Life Cycle*



Benchmarking Assessment Tool

<u>Regulatory</u>	vs	<u>Benchmarking</u>
Specific	-	Holistic
Single Location	-	Supply Chain
Quantitative	-	Qualitative
Reactive	-	Pro-Active



Benchmarking Assessment Tool

Questions

1. Is this an acceptable practice?
2. How would you monitor that situation?
3. Is the task or operation necessary?
4. What recommendation could improve performance?



Benchmarking Assessment Tool

Benchmark Phases for ULAB Recycling

- ❖ *ULAB Collection*
- ❖ *Temporary Storage*
- ❖ *Packaging*
- ❖ *Transportation*
- ❖ *Recycling*



Benchmarking Assessment Tool

Use of the Benchmarking Tool

- ❖ *Practical Application*

- ✓ *Complete the Assessment Form*



Benchmarking Assessment Tool

No.	Collection and Supply Points	A	B	C	D
1	What Used Lead Acid Batteries (ULAB) are being collected?	Car	Motorcycle	UPS/Security Garages	Industrial Scrap Dealer
2	How are ULAB collected?	Citizens	Retailers	Garages	Scrap Dealer
3	How are the ULAB delivered? Drained of Acid or complete with Acid?	Drained	Some drained	A few drained	Complete
4	How are the ULAB sorted?	Size	Plastic case	Automotive	Industrial
5	Are ULAB that leak separated and packed in plastic containers?	No	Sometimes	Drained first	Always
6	What happens to the ULAB collected?	Tested and recharged	Reconditioned	Sold	Packaged & shipped
7	How are ULAB stored while waiting for dispatch to the recycler?	In the open	Packaged in the open	Under cover	Packaged & under cover
8	How are ULAB collected transported to the recycling plant?	Bicycle/cart	Open truck	Closed truck/van	Licensed truck/van
9	How are the ULAB packed onto or into the vehicle for transport to the recycling plant?	Loose	Loose and upright	Palletized & wrapped	As C with leaking ULAB in a leak proof container.

2 of 5 - ULAB Collection and Supply Points



Benchmarking Assessment Tool

Use of the Benchmarking Tool

- ❖ *Practical Application*

- ✓ *Complete the Assessment Form*

- ✓ *Identify the Key Benchmarks*



Benchmarking Assessment Tool

No.	Collection and Supply Points	A	B	C	D
1	What Used Lead Acid Batteries (ULAB) are being collected?	Car	Motorcycle	UPS/Security Garages	Industrial Scrap Dealer
2	How are ULAB collected?	Citizens	Retailers	Garages	Scrap Dealer
3	How are the ULAB delivered? Drained of Acid or complete with Acid?	Drained	Some drained	A few drained	Complete
4	How are the ULAB sorted?	Size	Plastic case	Automotive	Industrial
5	Are ULAB that leak separated and packed in plastic containers?	No	Sometimes	Drained first	Always
6	What happens to the ULAB collected?	Tested and recharged	Reconditioned	Sold	Packaged & shipped
7	How are ULAB stored while waiting for dispatch to the recycler?	In the open	Packaged in the open	Under cover	Packaged & under cover
8	How are ULAB collected transported to the recycling plant?	Bicycle/cart	Open truck	Closed truck/van	Licensed truck/van
9	How are the ULAB packed onto or into the vehicle for transport to the recycling plant?	Loose	Loose and upright	Palletized & wrapped	As C with leaking ULAB in a leak proof container.

2 of 5 - ULAB Collection and Supply Points



Benchmarking Assessment Tool

No.	Collection and Supply Points	A	B	C	D
1	What Used Lead Acid Batteries (ULAB) are being collected?	Car	Motorcycle	UPS/Security	Industrial
3	How are the ULAB delivered? Drained of Acid or complete with Acid?				
5	Are ULAB that leak separated and packed in plastic containers?	No	Sometimes	Drained first	Always
6	What happens to the ULAB collected?	Tested and recharged	Reconditioned	Sold	Packaged & shipped
7	How are ULAB stored while waiting for dispatch to the recycler?	In the open	Packaged in the open	Under cover	Packaged & under cover
8	How are ULAB collected transported to the recycling plant?	Bicycle/cart	Open truck	Closed truck/van	Licensed truck/van
9	How are the ULAB packed onto or into the vehicle for transport to the recycling plant?	Loose	Loose and upright	Palletized & wrapped	As C with leaking ULAB in a leak proof container.

2 of 5 - ULAB Collection and Supply Points

Benchmarking Assessment Tool

Use of the Benchmarking Tool

- ❖ *Practical Application*
- ✓ *Complete the Assessment Form*
- ✓ *Identify the Key Benchmarks*
- ✓ *Determine Compliance with Benchmarks*

Benchmarking Assessment Tool

No.	Collection and Supply Points	A	B	C	D
1	What Used Lead Acid Batteries (ULAB) are being collected?	Car	Motorcycle	UPS/Security	Industrial
		Drained	Some Drained	A few drained	Complete
5	Are ULAB that leak separated and packed in plastic containers?	No	Sometimes	Drained first	Always
6	What happens to the ULAB collected?	Tested and recharged	Reconditioned	Sold	Packaged & shipped
7	How are ULAB stored while waiting for dispatch to the recycler?	In the open	Packaged in the open	Under cover	Packaged & under cover
8	How are ULAB collected transported to the recycling plant?	Bicycle/cart	Open truck	Closed truck/van	Licensed truck/van
9	How are the ULAB packed onto or into the vehicle for transport to the recycling plant?	Loose	Loose and upright	Palletized & wrapped	As C with leaking ULAB in a leak proof container.

2 of 5 - ULAB Collection and Supply Points

Benchmarking Assessment Tool

No.	Collection and Supply Points	A	B	C	D
1	What Used Lead Acid Batteries (ULAB) are being collected?	Car	Motorcycle	UPS/Security	Industrial
2	How are ULAB collected?	Citizens	Retailers	Garages	Scrap Dealer
3	How are the ULAB delivered? Drained of Acid or complete with Acid?	Drained	Some drained	A few drained	Complete
4	How are the ULAB sorted?	Size	Plastic case	Automotive	Industrial
5	Are ULAB that leak separated and packed in plastic containers?	No	Sometimes	Drained first	Always
6	What happens to the ULAB collected?	Tested and recharged	Reconditioned	Sold	Packaged & shipped
7	How are ULAB stored while waiting for dispatch to the recycler?	In the open	Packaged in the open	Under cover	Packaged & under cover
8	How are ULAB collected transported to the recycling plant?	Bicycle/cart	Open truck	Closed truck/van	Licensed truck/van
9	How are the ULAB packed onto or into the vehicle for transport to the recycling plant?	Loose	Loose and upright	Palletized & wrapped	As C with leaking ULAB in a leak proof container.

2 of 5 - ULAB Collection and Supply Points

Benchmarking Assessment Tool

No.	Collection and Supply Points	A	B	C	D
1	What Used Lead Acid Batteries (ULAB) are being collected?	Car	Motorcycle	UPS/Security	Industrial
2	How are ULAB collected?	Citizens	Retailers	Garages	Scrap Dealer
3	How are the ULAB delivered? Drained of Acid or complete with Acid?	Drained	Some drained	A few drained	Complete
4	How are the ULAB sorted?	Size	Plastic case	Automotive	Industrial
5	Are ULAB that leak separated and packed in plastic containers?	No	Sometimes	Drained first	Always
6	What happens to the ULAB collected?	Tested and recharged	Reconditioned	Sold	Packaged & shipped
7	How are ULAB stored while waiting for dispatch to the recycler?	In the open	Packaged in the open	Under cover	Packaged & under cover
8	How are ULAB collected transported to the recycling plant?				
9	How are the ULAB packed onto or into the vehicle for transport to the recycling plant?	Loose	Loose and upright	Palletized & wrapped	As C with leaking ULAB in a leak proof container.

2 of 5 - ULAB Collection and Supply Points

Benchmarking Assessment Tool

No.	Collection and Supply Points	A	B	C	D
1	What Used Lead Acid Batteries (ULAB) are being collected?	Car	Motorcycle	UPS/Security	Industrial
2	How are ULAB collected?	Citizens	Retailers	Garages	Scrap Dealer
3	How are the ULAB delivered? Drained of Acid or complete with Acid?	Drained	Some drained	A few drained	Complete
4	How are the ULAB sorted?	Size	Plastic case	Automotive	Industrial
5	Are ULAB that leak separated and packed in plastic containers?	No	Sometimes	Drained first	Always
6	What happens to the ULAB collected?	Tested and recharged	Reconditioned	Sold	Packaged & shipped
7	How are ULAB stored while waiting for dispatch to the recycler?	In the open	Packaged in the open	Under cover	Packaged & under cover
		Bicycle/Cart	Open Truck	Truck/Van	Licensed Truck/Van
9	How are the ULAB packed onto or into the vehicle for transport to the recycling plant?	Loose	Loose and upright	Palletized & wrapped	As C with leaking ULAB in a leak proof container.

2 of 5 - ULAB Collection and Supply Points

Benchmarking Assessment Tool

Collection and Supply Points

No.	Question	A	B	C	D
1	What Used Lead Acid Batteries (ULAB) are being collected?	Citizens	Homeowners	ULAB Recyclers	Industrial
2	How are ULAB collected?	Drained	Some drained	A few drained	Complete
3	How are the ULAB delivered? Drained of Acid or complete with Acid?	Size	Plastic case	Automotive	Industrial
4	How are the ULAB sorted?	No	Sometimes	Drained first	Always
5	Are ULAB that leak separated and packed in plastic containers?	Tested and recharged	Reconditioned	Sold	Packaged & stored
6	What happens to the ULAB collected?	In the open	Packaged in the open	Under cover	Packaged & under cover
7	How are ULAB stored while waiting for dispatch to the recycler?	Bicycle/cart	Open truck	Closed truck/van	Licensed truck/van
8	How are ULAB collected transported to the recycling plant?	Loose	Loose and upright	Palletized & wrapped	ULAB in a leak proof container
9	How are the ULAB packed onto or into the vehicle for transport to the recycling plant?				

2 of 5 - ULAB Collection and Supply Points

Benchmarking Assessment Tool

Use of the Benchmarking Tool

Practical Application

- Complete the Assessment Form
- Identify the Key Benchmarks
- Determine Compliance with Benchmarks
- Repeat for each section of the Form

Benchmarking Assessment Tool

Environmental Status

No.	Question	A	B	C	D
1	What agencies issue your environmental and operating licenses?	Health	Environment	Business	Other
2	How close is the general population to the Recycling Plant?	Next to the Plant	1 kilometre	5 Kilometres	Industrial Zone
3	Is process effluent discharged from the site?	Always and untreated	Sometimes untreated	After treatment	Never
4	What happens to the battery acid drained from the ULAB?	Discharged	Treated and discharged	Collected, treated and used in the process	Collected to produce Gypsum
5	How are furnace emissions from the plant controlled?	No control	Furnace is ventilated to a baghouse	All processes are ventilated to a Baghouse	As C with all fume recycled
6	If your plant is using a Blast Furnace - Do you have a Scrubber Unit?	No	Yes		
7	If your plant is using a Rotary Furnace - Do you add iron to the charge Material?	No	Yes		
8	What do you do with your furnace residues?	Dispose of in a local tip	Treat and dispose of in a local tip	Treated and sold for hard core	Treated and used to make bricks/tiles
9	Is the site clean, tidy and free of dust, slag and acid residues?	No	Dust and Slag only	Acid residues only	Yes

3 of 5 - Environmental Status

Benchmarking Assessment Tool

Environmental Status

No.	Question	A	B	C	D
1	What agencies issue your environmental and operating licenses?	Health	Environment	Business	Other
2	How close is the general population to the Recycling Plant?	Next to the Plant	1 kilometre	5 Kilometres	Industrial Zone
3	Is process effluent discharged from the site?	Always and untreated	Sometimes untreated	After treatment	Never
4	What happens to the battery acid drained from the ULAB?	Discharged	Treated and discharged	Collected, treated and used in the process	Collected to produce Gypsum
5	How are furnace emissions from the plant controlled?	No control	Furnace is ventilated to a baghouse	All processes are ventilated to a Baghouse	As C with all fume recycled
6	If your plant is using a Blast Furnace - Do you have a Scrubber Unit?	No	Yes		
7	If your plant is using a Rotary Furnace - Do you add iron to the charge Material?	No	Yes		
8	What do you do with your furnace residues?	Dispose of in a local tip	Treat and dispose of in a local tip	Treated and sold for hard core	Treated and used to make bricks/tiles
9	Is the site clean, tidy and free of dust, slag and acid residues?	No	Dust and Slag only	Acid residues only	Yes

3 of 5 - Environmental Status

Benchmarking Assessment Tool

Environmental Status

No.	Question	A	B	C	D
1	What agencies issue your environmental and operating licenses?	Health	Environment	Business	Other
2	How close is the general population to the Recycling Plant?	Next to the Plant	1 kilometre	5 Kilometres	Industrial Zone
3	Is process effluent discharged from the site?	Always and untreated	Sometimes untreated	After treatment	Never
4	What happens to the battery acid drained from the ULAB?	Discharged	Treated and discharged	Collected, treated and used in the process	Collected to produce Gypsum
5	How are furnace emissions from the plant controlled?	No control	Furnace is ventilated to a baghouse	All processes are ventilated to a Baghouse	As C with all fume recycled
6	If your plant is using a Blast Furnace - Do you have a Scrubber Unit?	No	Yes		
7	If your plant is using a Rotary Furnace - Do you add iron to the charge Material?	No	Yes		
8	What do you do with your furnace residues?	Dispose of in a local tip	Treat and dispose of in a local tip	Treated and sold for hard core	Treated and used to make bricks/tiles
9	Is the site clean, tidy and free of dust, slag and acid residues?	No	Dust and Slag only	Acid residues only	Yes

3 of 5 - Environmental Status

Benchmarking Assessment Tool

Environmental Status

No.	Question	A	B	C	D
1	What agencies issue your environmental and operating licenses?	Health	Environment	Business	Other
2	How close is the general population to the Recycling Plant?	Next to the Plant	1 kilometre	5 Kilometres	Industrial Zone
3	Is process effluent discharged from the site?	Always and untreated	Sometimes untreated	After treatment	Never
4	What happens to the battery acid drained from the ULAB?	Discharged	Treated and discharged	Collected, treated and used in the process	Collected to produce Gypsum
5	How are furnace emissions from the plant controlled?	No control	Furnace is ventilated to a baghouse	All processes are ventilated to a Baghouse	As C with all fume recycled
6	If your plant is using a Blast Furnace - Do you have a Scrubber Unit?	No	Yes		
7	If your plant is using a Rotary Furnace - Do you add iron to the charge Material?	No	Yes		
8	What do you do with your furnace residues?	Dispose of in a local tip	Treat and dispose of in a local tip	Treated and sold for hard core	Treated and used to make bricks/tiles
9	Is the site clean, tidy and free of dust, slag and acid residues?	No	Dust and Slag only	Acid residues only	Yes

3 of 5 - Environmental Status

Benchmarking Assessment Tool

No.	Occupational Lead Exposure	A	B	C	D
1	Is there a hygiene and respirator policy?	No	Respirator only	Hygiene only	Yes
2	Are respirators worn by all personnel in the operating areas	No	Some do	Only operating personnel	All personnel
3	Is there a Medical Officer and/or Occupational Nurse appointed to check the health of the workers?	No	On request	Nurse only	Yes
4	Are the occupational Lead in Blood levels checked?	Never	Annually	Twice annually	Every quarter
5	Do you communicate health risks to employees?	Never	If asked	Induction	Regularly
6	Are operating personnel issued with works clothing?	No	Overalls	Overalls, hat	Overalls, hat, boots & gloves
7	If so, how often are the clothes washed and changed?	Never	Every month	Every week	Every shift
8	Are eating and process areas segregated?	No	Eating on site is not permitted	Yes, but not ventilated	Yes with HEPA Air conditioning
9	Are there showers on site for use by the operators?	No, but there is a washroom	Yes, one shower	Yes, but it is not compulsory	Yes and it is compulsory

4 of 5 – Occupational Lead Exposure

Benchmarking Assessment Tool

No.	Occupational Lead Exposure	A	B	C	D
1	Is there a hygiene and respirator policy?	No	Respirator only	Hygiene only	Yes
2	Are respirators worn by all personnel in the operating areas	No	Some do	Only operating personnel	All personnel
3	Is there a Medical Officer and/or Occupational Nurse appointed to check the health of the workers?	No	On request	Nurse only	Yes
4	Are the occupational Lead in Blood levels checked?	Never	Annually	Twice annually	Every quarter
5	Do you communicate health risks to employees?	Never	If asked	Induction	Regularly
6	Are operating personnel issued with works clothing?	No	Overalls	Overalls, hat	Overalls, hat, boots & gloves
7	If so, how often are the clothes washed and changed?	Never	Every month	Every week	Every shift
8	Are eating and process areas segregated?	No	Eating on site is not permitted	Yes, but not ventilated	Yes with HEPA Air conditioning
9	Are there showers on site for use by the operators?	No, but there is a washroom	Yes, one shower	Yes, but it is not compulsory	Yes and it is compulsory

4 of 5 – Occupational Lead Exposure

Benchmarking Assessment Tool

No.	Occupational Lead Exposure	A	B	C	D
1	Is there a hygiene and respirator policy?	No	Respirator only	Hygiene only	Yes
2	Are respirators worn by all personnel in the operating areas	No	Some do	Only operating personnel	All personnel
3	Is there a Medical Officer and/or Occupational Nurse appointed to check the health of the workers?	No	On request	Nurse only	Yes
4	Are the occupational Lead in Blood levels checked?	Never	Annually	Twice annually	Every quarter
5	Do you communicate health risks to employees?	Never	If asked	Induction	Regularly
6	Are operating personnel issued with works clothing?	No	Overalls	Overalls, hat	Overalls, hat, boots & gloves
7	If so, how often are the clothes washed and changed?	Never	Every month	Every week	Every shift
8	Are eating and process areas segregated?	No	Eating on site is not permitted	Yes, but not ventilated	Yes with HEPA Air conditioning
9	Are there showers on site for use by the operators?	No, but there is a washroom	Yes, one shower	Yes, but it is not compulsory	Yes and it is compulsory

4 of 5 – Occupational Lead Exposure

Benchmarking Assessment Tool

No.	Occupational Lead Exposure	A	B	C	D
1	Is there a hygiene and respirator policy?	No	Respirator only	Hygiene only	Yes
2	Are respirators worn by all personnel in the operating areas	No	Some do	Only operating personnel	All personnel
3	Is there a Medical Officer and/or Occupational Nurse appointed to check the health of the workers?	No	On request	Nurse only	Yes
4	Are the occupational Lead in Blood levels checked?	Never	Annually	Twice annually	Every quarter
5	Do you communicate health risks to employees?	Never	If asked	Induction	Regularly
6	Are operating personnel issued with works clothing?	No	Overalls	Overalls, hat	Overalls, hat, boots & gloves
7	If so, how often are the clothes washed and changed?	Never	Every month	Every week	Every shift
8	Are eating and process areas segregated?	No	Eating on site is not permitted	Yes, but not ventilated	Yes with HEPA Air conditioning
9	Are there showers on site for use by the operators?	No, but there is a washroom	Yes, one shower	Yes, but it is not compulsory	Yes and it is compulsory

4 of 5 – Occupational Lead Exposure

Benchmarking Assessment Tool

No.	Safety	A	B	C	D
1	Is there a Safety Policy published and available for inspection?	No	In a safety folder	On display on site	On display and on the web site
2	Are there regular Safety Inspections & Audits?	No	Sometimes after an accident	Inspections but no audits	annually
3	Does every employee & contractor undergo a Safety Induction?	No	Employees only	Contractors only	Everybody
4	Have risk assessments been carried out for each operation?	No	Only for the EIA	Only for ISO 9001	Yes
5	Is there a record of every accident on site?	No	There is an accident book	Some accidents are recorded	Yes in the accident book
6	Is every accident investigated?	No	Yes, by the plant manager	Yes, by the insurance company	Yes, by a joint management & worker team
7	Is there a Permit to Work and Lock-Off system for maintenance?	No	Permit to work only	Lock-off only	Yes and with keys and locks
8	What Fire Precautions & Procedures are in place?	None	There are fire extinguishers	There are sand buckets	There are extinguishers & sand buckets
9	Is there a Safety Policy published and available for inspection?	No	In a safety folder	On display on site	On display and on the web site

5 of 5 – Safety

Benchmarking Assessment Tool

No.	Safety	A	B	C	D
1	Is there a Safety Policy published and available for inspection?	No	In a safety folder	On display on site	On display and on the web site
2	Are there regular Safety Inspections & Audits?	No	Sometimes after an accident	Inspections but no audits	annually
3	Does every employee & contractor undergo a Safety Induction?	No	Employees only	Contractors only	Everybody
4	Have risk assessments been carried out for each operation?	No	Only for the EIA	Only for ISO 9001	Yes
5	Is there a record of every accident on site?	No	There is an accident book	Some accidents are recorded	Yes in the accident book
6	Is every accident investigated?	No	Yes, by the plant manager	Yes, by the insurance company	Yes, by a joint management & worker team
7	Is there a Permit to Work and Lock-Off system for maintenance?	No	Permit to work only	Lock-off only	Yes and with keys and locks
8	What Fire Precautions & Procedures are in place?	None	There are fire extinguishers	There are sand buckets	There are extinguishers & sand buckets
9	Is there a Safety Policy published and available for inspection?	No	In a safety folder	On display on site	On display and on the web site

5 of 5 – Safety

Benchmarking Assessment Tool

No.	Safety	A	B	C	D
1	Is there a Safety Policy published and available for inspection?	No	In a safety folder	On display on site	On display and on the web site
2	Are there regular Safety Inspections & Audits?	No	Sometimes after an accident	Inspections but no audits	annually
3	Does every employee & contractor undergo a Safety induction?	No	Employees only	Contractors only	Everybody
4	Have risk assessments been carried out for each operation?	No	Only for the EIA	Only for ISO 9001	Yes
5	Is there a record of every accident on site?	No	There is an accident book	Some accidents are recorded	Yes in the accident book

No	Permit to work only	Lock-Off only	Yes with keys & locks
----	---------------------	---------------	----------------------------------

5 of 5 – Safety

Benchmarking Assessment Tool

No.	Safety	A	B	C	D
1	Is there a Safety Policy published and available for inspection?	No	In a safety folder	On display on site	On display and on the web site
2	Are there regular Safety Inspections & Audits?	No	Sometimes after an accident	Inspections but no audits	annually
3	Does every employee & contractor undergo a Safety induction?	No	Employees only	Contractors only	Everybody
4	Have risk assessments been carried out for each operation?	No	Only for the EIA	Only for ISO 9001	Yes
5	Is there a record of every accident on site?	No	There is an accident book	Some accidents are recorded	Yes in the accident book
6	Is every accident investigated?	No	Yes, by the plant manager	Yes, by the insurance company	Yes, by the management & company
7	Is there a Permit to Work and Lock-Off system for maintenance?	No	Permit to work only	Lock-off only	Yes and with keys and locks
8	What Fire Precautions & Procedures are in place?	None	There are fire extinguishers	There are sand buckets	There are extinguishers & sand buckets
9	Is there a Safety Policy published and available for inspection?	No	In a safety folder	On display on site	On display and on the web site

No	Permit to work only	Lock-Off only	Yes with keys & locks
----	---------------------	---------------	----------------------------------

5 of 5 – Safety

Benchmarking Assessment Tool

Use of the Benchmarking Tool

- ❖ Practical Application
- ✓ Complete the Assessment Form
- ✓ Identify the Key Benchmarks
- ✓ Determine Compliance with Benchmarks
- ✓ Identify Non-Compliance Issues
- ✓ Prepare recommendations to improve

Benchmarking Assessment Tool

No.	Collection and Supply Points	A	B	C	D
1	What Used Lead Acid Batteries (ULAB) are being collected?	Car	Motorcycle	UPS/Security	Industrial
3	How are the ULAB delivered? Drained of Acid or complete with Acid?				
5	Are ULAB that leak separated and packed in plastic containers?	No	Sometimes	Drained first	Always
6	What happens to the ULAB collected?	Tested and recharged	Reconditioned	Sold	Packaged & shipped
7	How are ULAB stored while waiting for dispatch to the recycler?	In the open	Packaged in the open	Under cover	Packaged & under cover
8	How are ULAB collected transported to the recycling plant?	Bicycle/cart	Open truck	Closed truck/van	Licensed truck/van
9	How are the ULAB packed onto or into the vehicle for transport to the recycling plant?	Loose	Loose and upright	Palletized & wrapped	As C with leaking ULAB in a leak proof container.

2 of 5 - ULAB Collection and Supply Points

Benchmarking Assessment Tool

No.	Collection and Supply Points	A	B	C	D
1	What Used Lead Acid Batteries (ULAB) are being collected?	Car	Motorcycle	UPS/Security	Industrial
3	How are the ULAB delivered? Drained of Acid or complete with Acid?				
5	Are ULAB that leak separated and packed in plastic containers?	No	Sometimes	Drained first	Always
6	What happens to the ULAB collected?	Tested and recharged	Reconditioned	Sold	Packaged & shipped
7	How are ULAB stored while waiting for dispatch to the recycler?	In the open	Packaged in the open	Under cover	Packaged & under cover
8	How are ULAB collected transported to the recycling plant?	Bicycle/cart	Open truck	Closed truck/van	Licensed truck/van
9	How are the ULAB packed onto or into the vehicle for transport to the recycling plant?	Loose	Loose and upright	Palletized & wrapped	As C with leaking ULAB in a leak proof container.

Drained	Some Drained	A few drained	Complete
---------	---------------------	---------------	----------

2 of 5 - ULAB Collection and Supply Points

Benchmarking Assessment Tool

No.	Collection and Supply Points	A	B	C	D
1	What Used Lead Acid Batteries (ULAB) are being collected?	Car	Motorcycle	UPS/Security	Industrial
3	How are the ULAB delivered? Drained of Acid or complete with Acid?				
5	Are ULAB that leak separated and packed in plastic containers?	No	Sometimes	Drained first	Always
6	What happens to the ULAB collected?	Tested and recharged	Reconditioned	Sold	Packaged & shipped
7	How are ULAB stored while waiting for dispatch to the recycler?	In the open	Packaged in the open	Under cover	Packaged & under cover
8	How are ULAB collected transported to the recycling plant?	Bicycle/cart	Open truck	Closed truck/van	Licensed truck/van
9	How are the ULAB packed onto or into the vehicle for transport to the recycling plant?	Loose	Loose and upright	Palletized & wrapped	As C with leaking ULAB in a leak proof container.

Drained	Some Drained	A few drained	Complete
---------	---------------------	---------------	----------

2 of 5 - ULAB Collection and Supply Points

Benchmarking Assessment Tool

No.	Collection and Supply Points	A	B	C	D
1	What Used Lead Acid Batteries (ULAB) are being collected?	Car	Motorcycle	UPS/Security	Industrial
2	How are ULAB collected?	Citizens	Retailers	Garages	Scrap Dealer
3	How are the ULAB delivered? Drained of Acid or complete with Acid?	Drained	Some drained	A few drained	Complete
4	How are the ULAB sorted?	Size	Plastic case	Automotive	Industrial
5	Are ULAB that leak separated and packed in plastic containers?	No	Sometimes	Drained first	Always
6	What happens to the ULAB collected?	Tested and recharged	Reconditioned	Sold	Packaged & shipped
How are ULAB stored while waiting for vehicle for transport to the recycling plant?					
8	How are ULAB collected transported to the recycling plant?	Loose	upright	wrapped	a leak proof container.

2 of 5 - ULAB Collection and Supply Points

Benchmarking Assessment Tool

No.	Collection and Supply Points	A	B	C	D
1	What Used Lead Acid Batteries (ULAB) are being collected?	Car	Motorcycle	UPS/Security	Industrial
2	How are ULAB collected?	Citizens	Retailers	Garages	Scrap Dealer
3	How are the ULAB delivered? Drained of Acid or complete with Acid?	Drained	Some drained	A few drained	Complete
4	How are the ULAB sorted?	Size	Plastic case	Automotive	Industrial
5	Are ULAB that leak separated and packed in plastic containers?	No	Sometimes	Drained first	Always
6	What happens to the ULAB collected?	Tested and recharged	Reconditioned	Sold	Packaged & shipped
How close is the general population to the vehicle for transport to the recycling plant?					
8	How are ULAB collected transported to the recycling plant?	Bicycle/Cart	Open Truck	Truck/Van	Licensed Truck/Van

2 of 5 - ULAB Collection and Supply Points

Benchmarking Assessment Tool

No.	Environmental Status	A	B	C	D
1	What agencies issue your environmental and operating licenses?	Health	Environment	Business	Other
How close is the general population to the site?					
3	Is process effluent discharged from the site?	discharged	discharged	discharged	discharged
5	How are furnace emissions from the plant controlled?	No control	Furnace is ventilated to a baghouse	All processes are ventilated to a Baghouse	As C with all fume recycled
6	If your plant is using a Blast Furnace – Do you have a Scrubber Unit?	No	Yes		
7	If your plant is using a Rotary Furnace – Do you add iron to the charge Material?	No	Yes		
8	What do you do with your furnace residues?	Dispose of in a local tip	Treat and dispose of in a local tip	Treated and sold for hard core	Treated and used to make bricks/tiles
9	Is the site clean, tidy and free of dust, slag and acid residues?	No	Dust and Slag only	Acid residues only	Yes

3 of 5 – Environmental Status

Benchmarking Assessment Tool

No.	Environmental Status	A	B	C	D
1	What agencies issue your environmental and operating licenses?	Health	Environment	Business	Other
How close is the general population to the site?					
3	Is process effluent discharged from the site?	Always and untreated	Sometimes untreated	After treatment	Never
5	How are furnace emissions from the plant controlled?	No control	Furnace is ventilated to a baghouse	All processes are ventilated to a Baghouse	As C with all fume recycled
6	If your plant is using a Blast Furnace – Do you have a Scrubber Unit?	No	Yes		
7	If your plant is using a Rotary Furnace – Do you add iron to the charge Material?	No	Yes		
8	What do you do with your furnace residues?	Dispose of in a local tip	Treat and dispose of in a local tip	Treated and sold for hard core	Treated and used to make bricks/tiles
9	Is the site clean, tidy and free of dust, slag and acid residues?	No	Dust and Slag only	Acid residues only	Yes

3 of 5 – Environmental Status

Benchmarking Assessment Tool

No.	Environmental Status	A	B	C	D
1	What agencies issue your environmental and operating licenses?	Health	Environment	Business	Other
How close is the general population to the site?					
3	Is process effluent discharged from the site?	Always and untreated	Sometimes untreated	After treatment	Never
5	How are furnace emissions from the plant controlled?	No control	Furnace is ventilated to a baghouse	All processes are ventilated to a Baghouse	As C with all fume recycled
6	If your plant is using a Blast Furnace – Do you have a Scrubber Unit?	No	Yes		
7	If your plant is using a Rotary Furnace – Do you add iron to the charge Material?	No	Yes		
8	What do you do with your furnace residues?	Dispose of in a local tip	Treat and dispose of in a local tip	Treated and sold for hard core	Treated and used to make bricks/tiles
9	Is the site clean, tidy and free of dust, slag and acid residues?	No	Dust and Slag only	Acid residues only	Yes

3 of 5 – Environmental Status

Benchmarking Assessment Tool

No.	Occupational Lead Exposure	A	B	C	D
1	Is there a hygiene and respirator policy?	No	Respirator only	Hygiene only	Yes
2	Are respirators worn by all personnel in the operating areas?	No	Some do	Only operating personnel	All personnel
3	Is there a Medical Officer and/or Occupational Nurse appointed to check the health of the workers?	No	On request	Nurse only	Yes
4	Are the occupational Lead in Blood levels checked?	Never	Annually	Twice annually	Every quarter
5	Do you communicate health risks to employees?	Never	If asked	Induction	Regularly
6	Are operating personnel issued with works clothing? If so, how often are the clothes washed and	No	Overalls	Overalls, hat	Overalls, hat, boots & gloves
How close is the general population to the site?					
8	Are eating and process areas segregated?	washroom	Yes, one shower	compulsory	compulsory

4 of 5 – Occupational Lead Exposure

Benchmarking Assessment Tool

No.	Occupational Lead Exposure	A	B	C	D
1	Is there a hygiene and respirator policy?	No	Respirator only	Hygiene only	Yes
2	Are respirators worn by all personnel in the operating areas	No	Some do	Only operating personnel	All personnel
3	Is there a Medical Officer and/or Occupational Nurse appointed to check the health of the workers?	No	On request	Nurse only	Yes
4	Are the occupational Lead in Blood levels checked?	Never	Annually	Twice annually	Every quarter
5	Do you communicate health risks to employees?	Never	If asked	Induction	Regularly
6	Are operating personnel issued with works	No	Overalls, hat	Overalls, hat	Overalls, hat, HEPA A/C

No **Eating on site not permitted** **Yes, but not ventilated** **Yes with HEPA A/C**

9 Are there showers on site for use by the operators? No, but there is a washroom Yes, one shower Yes, but it is not compulsory Yes and it is compulsory

4 of 5 – Occupational Lead Exposure



Benchmarking Assessment Tool

No.	Safety	A	B	C	D
1	Is there a Safety Policy published and available for inspection?	No	In a safety folder	On display on site	On display and on the web site
2	Are there regular Safety Inspections & Audits?	No	Sometimes after an accident	Inspections but no audits	annually
3	Does every employee & contractor undergo a Safety Induction?	No	Employees only	Contractors only	Everybody
4	Have risk assessments been carried out for each operation?	No	Only for the EIA	Only for ISO 9001	Yes
5	Is there a record of every accident on site?	No	There is an accident book	Some accidents	Yes in the accident book
7	Is there a Permit to Work and Lock-Off system for maintenance?	No	Lock-Off only	Keys and locks	Keys and locks
8	What Fire Precautions & Procedures are in place?	None	There are fire extinguishers	There are sand buckets	There are extinguishers & sand buckets
9	Is there a Safety Policy published and available for inspection?	No	In a safety folder	On display on site	On display and on the web site

5 of 5 – Safety





Benchmarking Assessment Tool

No.	Safety	A	B	C	D
1	Is there a Safety Policy published and available for inspection?	No	In a safety folder	On display on site	On display and on the web site
2	Are there regular Safety Inspections & Audits?	No	Sometimes after an accident	Inspections but no audits	annually
3	Does every employee & contractor undergo a Safety Induction?	No	Employees only	Contractors only	Everybody
4	Have risk assessments been carried out for each operation?	No	Only for the EIA	Only for ISO 9001	Yes
5	Is there a record of every accident on site?	No	There is an accident book	Some accidents are recorded	Yes in the accident book
7	Is there a Permit to Work and Lock-Off system for maintenance?	No	Lock-Off only	Keys and locks	Keys and locks
8	What Fire Precautions & Procedures are in place?	None	There are fire extinguishers	There are sand buckets	There are extinguishers & sand buckets
9	Is there a Safety Policy published and available for inspection?	No	In a safety folder	On display on site	On display and on the web site

No **Permit to work only** **Lock-Off only** **Yes with keys & locks**

5 of 5 – Safety



- ### BAT Recommendations
- Short Term – Minimum or no cost**
 - Only purchase ULAB complete with electrolyte
 - License the ULAB collection truck
 - Short/Medium Term – Low Cost**
 - Neutralise & filter electrolyte prior to discharge
 - Install a +ve pressure HEPA filter for Canteen
 - Introduce a Lock-Off system for isolation
 - Long Term – Capital Investment**
 - Build an ETP and operate a closed loop system
- 

- ### Benchmarking Assessment Tool
- Conclusions:**
- ✓ Easy to use, fast and pro-active
 - ✓ Can identify HSE issues and problems
 - ✓ Process is qualitative & based on observation
 - ✓ Non – confrontational and drives ESM
 - ✓ Could be a useful indicator of ESM
- 